

# 工程名稱

HILTI HIT-RE 100 化學植筋工程  
品質管理與施工計畫書

材料廠商：喜利得股份有限公司

中 華 民 國



# 目 錄

- 一、 說明
- 二、 品質管理及拉拔試驗
  - (一) 品質管理
  - (二) 化學植筋或錨栓施工前或施工後拉拔試驗
- 三、 材料
  - (一) 化學黏著藥劑
- 四、 施工步驟
  - (一) 鑽孔
  - (二) 化學植筋或錨栓安裝
- 五、 附件說明



## 施工說明

### 一、 說明

本工程施工要點乃在原有結構之混凝土上鑽孔，注入化學黏著藥劑並旋入鋼筋或螺桿，以達到鋼筋或螺桿與原有結構混凝土結成一體之目的，增加設計之彈性，以達到新舊結構物結合之目的。

### 二、 品質管理及拉拔試驗

必要的品質管制與測試機制，可使得工程進展順利，更可以維持工程的品質，保障大眾權益，本化學藥劑品質管理及拉拔試驗均依據規範辦理。

#### (一) 品質管理

- A. 本植筋及化學錨栓工程使用之化學藥劑為 HILTI HIT-RE100，其使用期限標示於藥劑瓶蓋上。植筋施作前需注意藥劑是否在使用期限之內，逾期不得使用，並提供藥劑之購買與進口證明予工地工程司查核。
- B. 本化學藥劑 HILTI HIT-RE100 依照製造廠商之產品安全資料) 儲存方式保管，工地現場需放置於陰涼處所避免陽光直接照射，其產品安全資料需標明誤觸或誤食之處理方式，使用藥劑前施工人員應穿戴護目鏡及手套等防護措施。
- C. 本化學藥劑通過美國規範協會 ICC AC308 之認證報告，報告編號為 ICC ESR-3829(詳附件一)，其通過之測試項目詳報告中第 5 及 4 章節所述，內容包含通過潛變試驗(第 5.6 節 long-term loads ; AC308 第 7 項試驗)、潮濕試驗(第 4.1.4 節 water-saturated ; AC308 第 2f 項試驗)、耐震試驗(第 5.7 節 seismic design ; AC308 第 17、18 項試驗)、握裹性測試(第 4.1.4 節 bond strength determination ; AC308 第 1、11、16 項試驗)，本化學藥劑之耐震測試結果

喜利得股份有限公司

送審專用

FOR REVIEW

符合 IBC 或 IRC 規定之地震設計類別(Seismic Design Category : C, D, E 或 F)以及 UBC 規定之地震區域(Seismic Zone : 2B, 3, 4)。AC308 測試項目如 ESR-3829 後附件所述。其中 ICC AC308 之認證報告中,符合實驗標準 ASTM E 488-96 於允收標準第 1.3.22 節中說明為『ASTM E 488-96(2003), Standard Test Method for Strength of Anchors in Concrete and Masonry Elements, ASTM International.』如附件一第二頁。

- D. 拉拔試驗之試驗單位與儀器依規範辦理,詳細規定如下:
- a. 油壓千斤頂及手動幫浦,需提供財團法人全國認證基金會(TAF)或經濟部標準檢驗局認可之實驗單位或經濟部標準檢驗局認證通過之校正期限為一年內之校正報告。

## (二) 植筋及化學錨栓施工前或施工後拉拔試驗

- A. 設備:油壓千斤頂、手動幫浦、校正報告、夾具等。植筋試驗以同尺寸高拉力螺桿(CNS 3934 8.8 級)以不小於1.0倍鋼筋降伏拉力,化學錨栓以不小於1.0倍設計拉力為測試力量並,依規範要求之拉力在不同混凝土強度作測試(藥劑錨錠不可破壞),並紀錄孔深、使用藥劑品牌及型號。
- B. 試驗時,確定其樣本周圍表面平坦且與鋼筋垂直,以做為千斤頂施力時之反力。
- C. 將夾具固定再受測樣本上,再套入千斤頂並裝上夾具。測試時可依據實際情形,裝置腳座以方便測試進行。
- D. 將手動幫浦油壓管接上千斤頂,並旋緊閥門。
- E. 確定油壓錶歸零後由手動幫浦慢慢加壓,直到油壓錶達到試驗拉力所需值。
- F. 記錄並拍照存證後打開閥門,解除壓力,試驗完竣

驍利得股份有限公司  
送審專用  
FOR REVIEW

### 三、 材料

#### (一) 化學黏著藥劑

本化學藥劑為二劑型藥劑(主劑及硬化劑)，並符合規範規定，通過 ICC AC308 規範之握裹性、潛變、耐震及潮濕環境測試，ICC AC308 允收標準報告詳**附件一**， HILTI HIT-RE100 產品型錄詳**附件二**。

### 四、 施工步驟

#### (一) 鑽孔

1. 本藥劑進場經核可後方可使用。
2. 鑽孔應按照預定之順序及位置，使用電鎚鑽，連續鑽孔須達到規定之直徑、深度及角度。
3. 施工時於鑽孔過程中，如遇鋼筋及未達設計孔深而遇到既有鋼筋時，則此鑽孔予以廢棄不用，另行鑽孔，而廢孔以無收縮水泥砂漿填實。
4. 鑽孔完畢後用吹氣筒或其他空壓設備將孔內灰屑吹出。

#### (二) 化學植筋或化學錨栓安裝

1. 將本化學藥劑裝入注射器中，再將混合器安裝完成。若鑽孔深度超過混合器長度時，可加裝延長管（內附）使用。（使用新的藥劑包需廢棄前2~3次扣板機所流出的藥劑，以確保藥劑有充分混合）
2. 注射時深入孔底緩緩將化學藥劑打入孔內，依刻度邊打邊退，直到注入至少六分滿為止，再將準備好之鋼筋慢慢旋入孔內，直至底部且可目視藥劑外溢。
3. 化學植筋及錨栓施作完成後，應靜置避免擾動，待超過藥劑膠凝時間，即可硬化完成進行負載或施工。
4. 待施工完成後，必須經業主或監造人員檢驗合格，完成記錄備核。

喜利得股份有限公司

送審專用

FOR REVIEW





## 五、 附件說明

- (一) HILTI HIT-RE100 ICC 認證報告
  - 通過 ICC AC308 允收標準報告：ESR-3829
- (二) HILTI HIT-RE100 原廠型錄
- (三) 材料廠商公司資料
- (四) HILTI HIT-RE100 TAF 試驗報告
  - 黏著強度 ASTM C882/C882M-13a
  - 吸水率 ASTM D570-98(2010)<sup>e1</sup>
  - 接著強度 CNS 1010142 (1994)
  - 抗壓強度 CNS 1010142 (1994)
- (五) HILTI HIT-RE100 防腐蝕報告
- (六) ASTM E1512 及 E488 規範



附件一 HILTI HIT-RE100 長期潛變報告

-通過 ICC AC308 允收標準報告  
ESR-3829



**DIVISION: 03 00 00—CONCRETE**  
**Section: 03 16 00—Concrete Anchors**

**DIVISION: 05 00 00—METALS**  
**Section: 05 05 19—Post-Installed Concrete Anchors**

**REPORT HOLDER:**

HILTI, INC.

**EVALUATION SUBJECT:**

**HILTI HIT-RE 100 ADHESIVE ANCHORS AND POST INSTALLED REINFORCING BAR CONNECTIONS IN CRACKED AND UNCRACKED CONCRETE**

**1.0 EVALUATION SCOPE**

**Compliance with the following codes:**

- 2018, 2015, 2012, and 2009 *International Building Code*® (IBC)
- 2018, 2015, 2012, and 2009 *International Residential Code*® (IRC)

For evaluation for compliance with codes adopted by the Los Angeles Department of Building and Safety (LADBS), see [ESR-3829 LABC and LARC Supplement](#).

**Property evaluated:**

Structural

**2.0 USES**

The Hilti HIT-RE 100 Adhesive Anchoring System is used as anchorage in cracked and uncracked normal-weight concrete having a specified compressive strength,  $f'_c$ , of 2,500 psi to 8,500 psi (17.2 MPa to 58.6 MPa) to resist static, wind and earthquake (Seismic Design Categories A through F) tension and shear loads.

The anchor system complies with anchors as described in Section 1901.3 of the 2018 and 2015 IBC, Section 1909 of the 2012 IBC and is an alternative to cast-in-place and post-installed anchors described in Section 1908 of the 2012 IBC, and Sections 1911 and 1912 of the 2009. The anchor system may also be used where an engineered design is submitted in accordance with Section R301.1.3 of the IRC.

The Hilti HIT-RE 100 Post-Installed Reinforcing Bar system is an alternative to cast-in-place reinforcing bars governed by ACI 318 and IBC Chapter 19.

**3.0 DESCRIPTION**

**3.1 General:**

The Hilti HIT-RE 100 Adhesive Anchoring System and Post-Installed Reinforcing Bar System are comprised of the following components:

- Hilti HIT-RE 100 adhesive packaged in foil packs
- Adhesive mixing and dispensing equipment
- Equipment for hole cleaning and adhesive injection

The Hilti HIT-RE 100 Adhesive Anchoring System may be used with continuously threaded rod or deformed steel reinforcing bars as depicted in Figure 4. The Hilti HIT-RE 100 Post-Installed Reinforcing Bar system may only be used with deformed steel reinforcing bars. The primary components of the Hilti Adhesive Anchoring System, including the Hilti HIT-RE 100 Adhesive, HIT-RE-M static mixing nozzle and steel anchoring elements, are shown in Figure 6 of this report.

The manufacturer's printed installation instructions (MPII), as included with each adhesive unit package, are replicated as Figure 9 of this report.

**3.2 Materials:**

**3.2.1 Hilti HIT-RE 100 Adhesive:** Hilti HIT-RE 100 Adhesive is an injectable, two-component epoxy adhesive. The two components are separated by means of a dual-cylinder foil pack attached to a manifold. The two components combine and react when dispensed through a static mixing nozzle attached to the manifold. Hilti HIT-RE 100 is available in 11.1-ounce (330 ml), 16.9-ounce (500 ml), and 47.3-ounce (1400 ml) foil packs. The manifold attached to each foil pack is stamped with the adhesive expiration date. The shelf life, as indicated by the expiration date, applies to an unopened foil pack stored in a dry, dark environment and in accordance with Figure 9 of this report.

**3.2.2 Hole Cleaning Equipment:**

**3.2.2.1 Standard Equipment:** Standard hole cleaning equipment, comprised of steel wire brushes and air nozzles, is described in Figure 9 of this report.

**3.2.2.2 Hilti Safe-Set™ System:** For the elements described in Section 3.2.4, the Hilti TE-CD and TE-YD hollow carbide drill bit with a carbide drilling head conforming to ANSI B212.15 must be used. Used in conjunction with a Hilti vacuum with a minimum value for the maximum volumetric flow rate of 129 CFM (61 l/s), the Hilti TE-CD or TE-YD drill bit will remove the drilling dust, automatically cleaning the hole.

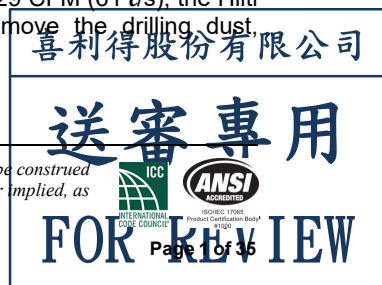

**3.2.3 Dispensers:** Hilti HIT-RE 100 must be dispensed with manual dispensers, pneumatic dispensers, or electric dispensers provided by Hilti.

### 3.2.4 Anchor Elements:

**3.2.4.1 Threaded Steel Rods:** Threaded steel rods must be clean, continuously threaded rods (all-thread) in diameters as described in Tables 4 and 9 and Figure 4 of this report. Steel design information for common grades of threaded rods is provided in Table 2. Carbon steel threaded rods must be furnished with a 0.0002-inch-thick (0.005 mm) zinc electroplated coating in compliance with ASTM B633 SC 1 or must be hot-dip galvanized in compliance with ASTM A153, Class C or D. Stainless steel threaded rods must comply with ASTM F593 or ISO 3506 A4. Threaded steel rods must be straight and free of indentations or other defects along their length. The ends may be stamped with identifying marks, and the embedded end may be blunt cut or cut on the bias to a chisel point.

**3.2.4.2 Steel Reinforcing Bars for use in Post-Installed Anchor Applications:** Steel reinforcing bars are deformed bars as described in Table 3 of this report. Tables 5, 9, and 13 and Figure 4 summarize reinforcing bar size ranges. The embedded portions of reinforcing bars must be straight, and free of mill scale, rust, mud, oil and other coatings (other than zinc) that may impair the bond with the adhesive. Reinforcing bars must not be bent after installation except as set forth in Section 26.6.3.1(b) of ACI 318-14 or Section 7.3.2 of ACI 318-11, as applicable, with the additional condition that the bars must be bent cold, and heating of reinforcing bars to facilitate field bending is not permitted.

**3.2.4.3 Ductility:** In accordance with ACI 318-14 2.3 or ACI 318-11 D.1, as applicable, in order for a steel element to be considered ductile, the tested elongation must be at least 14 percent and reduction of area must be at least 30 percent. Steel elements with a tested elongation of less than 14 percent or a reduction of area of less than 30 percent, or both, are considered brittle. Values for various steel materials are provided in Tables 2 and 3 of this report. Where values are nonconforming or unstated, the steel must be considered brittle.

**3.2.5 Steel Reinforcing Bars for use in Post-Installed Reinforcing Bar Connections:** Steel reinforcing bars used in post-installed reinforcing bar connections are deformed bars (rebar). Tables 16, 17, and 18 and Figure 4 summarize reinforcing bar size ranges. The embedded portions of reinforcing bars must be straight and free of millscale, rust, and other coatings that may impair the bond with the adhesive. Reinforcing bars must not be bent after installation, except as set forth in ACI 318-14 Section 26.6.3.1 (b) or ACI 318-11 Section 7.3.2, as applicable with the additional condition that the bars must be bent cold, and heating of reinforcing bars to facilitate field bending is not permitted.

### 3.3 Concrete:

Normal-weight concrete must comply with Sections 1903 and 1905 of the IBC, as applicable. The specified compressive strength of the concrete must be from 2,500 psi to 8,500 psi (17.2 MPa to 58.6 MPa).

## 4.0 DESIGN AND INSTALLATION

### 4.1 Strength Design of Post-Installed Anchors:

Refer to Table 1 for the design parameters for specific installed elements, and refer to Figure 5 and Section 4.1.4

for a flowchart to determine the applicable design bond strength or pullout strength.

**4.1.1 General:** The design strength of anchors under the 2018 and 2015 IBC, as well as the 2018 and 2015 IRC must be determined in accordance with ACI 318-14 Chapter 17 and this report.

Design strength of anchors complying with the 2012 and 2009 IBC and 2012 and 2009 IRC, must be in accordance with ACI 318-11 Appendix D and this report.

A design example according to the 2018 and 2015 IBC is included given in Figure 7.

Design parameters are provided in Tables 4 through 15 and based on ACI 318-14 for use with the 2018 and 2015 IBC, and ACI 318-11 for use with the 2012 and 2009 IBC unless noted otherwise in Sections 4.1.1 through 4.1.11 of this report.

The strength design of anchors must comply with ACI 318-14 17.3.1 or ACI 318-11 D.4.1, as applicable, except as required in ACI 318-14 17.2.3 or ACI 318-11 D.3.3, as applicable.

Strength reduction factors,  $\phi$ , as given in ACI 318-14 17.3.3 or ACI 318-11 D.4.3, as applicable, must be used for load combinations calculated in accordance with Section 1605.2 of the IBC or Section 5.3 of ACI 318-14 or Section 9.2 of ACI 318-11, as applicable. Strength reduction factors,  $\phi$ , as given in ACI 318-11 D.4.4 must be used for load combinations calculated in accordance with ACI 318 Appendix C.

**4.1.2 Static Steel Strength in Tension:** The nominal static steel strength of a single anchor in tension,  $N_{sa}$ , in accordance with ACI 318-14 17.4.1.2 or ACI 318-11 D.5.1.2, as applicable, and the associated strength reduction factors,  $\phi$ , in accordance with ACI 318-14 17.3.3 or ACI 318-11 D.4.3, as applicable, are provided in the tables outlined in Table 1 for the anchor element types included in this report.

**4.1.3 Static Concrete Breakout Strength in Tension:** The nominal concrete breakout strength of a single anchor or group of anchors in tension,  $N_{cb}$  or  $N_{cbg}$ , must be calculated in accordance with ACI 318-14 17.4.2 or ACI 318 D.5.2, as applicable, with the following addition:

The basic concrete breakout strength of a single anchor in tension,  $N_b$ , must be calculated in accordance with ACI 318-14 17.4.2.2 or ACI 318-11 D.5.2.2, as applicable, using the values of  $k_{c,cr}$ , and  $k_{c,uncl}$  as described in this report. Where analysis indicates no cracking in accordance with ACI 318-14 17.4.2.6 or ACI 318-11 D.5.2.6, as applicable,  $N_b$  must be calculated using  $k_{c,uncl}$  and  $\psi_{c,N} = 1.0$ , see Table 1. For anchors in lightweight concrete, see ACI 318-14 17.2.6 or ACI 318-11 D.3.6, as applicable. The value of  $f'_c$  used for calculation must be limited to 8,000 psi (55 MPa) in accordance with ACI 318-14 17.2.7 or ACI 318-11 D.3.7, as applicable. Additional information for the determination of nominal bond strength in tension is given in Section 4.1.4 of this report.

**4.1.4 Static Bond Strength in Tension:** The nominal static bond strength of a single adhesive anchor or group of adhesive anchors in tension,  $N_a$  or  $N_{ag}$ , must be calculated in accordance with ACI 318-14 17.4.5 or ACI 318-11 D.5.1.2, as applicable. Bond strength values are a function of the concrete compressive strength, whether the concrete is cracked or uncracked, the concrete temperature range, and

喜利得股份有限公司  
送審專用  
FOR REVIEW

the installation conditions (dry, water-saturated, etc.). The resulting characteristic bond strength shall be multiplied by the associated strength reduction factor  $\phi_{nn}$  as follows:

DRILLING METHOD	CONCRETE TYPE	PERMISSIBLE INSTALLATION CONDITIONS	BOND STRENGTH	ASSOCIATED STRENGTH REDUCTION FACTOR
Hammer-drill	Uncracked	Dry	$\tau_{k,uncr}$	$\phi_d$
		Water-saturated	$\tau_{k,uncr}$	$\phi_{ws}$
		Water-filled hole	$\tau_{k,uncr}$	$\phi_{wf}$
		Underwater application	$\tau_{k,uncr}$	$\phi_{uw}$
	Cracked	Dry	$\tau_{k,cr}$	$\phi_d$
		Water-saturated	$\tau_{k,cr}$	$\phi_{ws}$
		Water-filled hole	$\tau_{k,cr}$	$\phi_{wf}$
		Underwater application	$\tau_{k,cr}$	$\phi_{uw}$
Hammer-drill with Hiiti TE-YD or TE-CD Hollow Drill Bit	Uncracked	Dry	$\tau_{k,uncr}$	$\phi_d$
		Water-saturated	$\tau_{k,uncr}$	$\phi_{ws}$
	Cracked	Dry	$\tau_{k,cr}$	$\phi_d$
		Water-saturated	$\tau_{k,cr}$	$\phi_{ws}$

Figure 5 of this report presents a bond strength design selection flowchart. Strength reduction factors for determination of the bond strength are outlined in Table 7, 8, 11, 12 and 15 of this report. Adjustments to the bond strength may also be made for increased concrete compressive strength as noted in the footnotes to the bond strength tables.

**4.1.5 Static Steel Strength in Shear:** The nominal static strength of a single anchor in shear as governed by the steel,  $V_{sa}$ , in accordance with ACI 318-14 17.5.1.2 or ACI 318-11 D.6.1.2, as applicable, and strength reduction factors,  $\phi$ , in accordance with ACI 318-14 17.3.3 or ACI 318-11 D.4.3, as applicable, are given in the tables outlined in Table 1 for the anchor element types included in this report.

**4.1.6 Static Concrete Breakout Strength in Shear:** The nominal static concrete breakout strength of a single anchor or group of anchors in shear,  $V_{cb}$  or  $V_{cbg}$ , must be calculated in accordance with ACI 318-14 17.5.2 or ACI 318-11 D.6.2, as applicable, based on information given in the tables outlined in Table 1. The basic concrete breakout strength of a single anchor in shear,  $V_b$ , must be calculated in accordance with ACI 318-14 17.5.2.2 or ACI 318-11 D.6.2.2, as applicable, using the values of  $d$  given in the tables as outlined in Table 1 for the corresponding anchor steel in lieu of  $d_a$  (2018, 2015, 2012, and 2009 IBC). In addition,  $h_{ef}$  must be substituted for  $l_e$ . In no case must  $l_e$  exceed  $8d$ . The value of  $f'_c$  must be limited to a maximum of 8,000 psi (55 MPa) in accordance with ACI 318-14 17.2.7 or ACI 318-11 D.3.7, as applicable.

**4.1.7 Static Concrete Pryout Strength in Shear:** The nominal static pryout strength of a single anchor or group of anchors in shear,  $V_{cp}$  or  $V_{cpg}$ , must be calculated in accordance with ACI 318-14 17.5.3 or ACI 318-11 D.6.3, as applicable.

**4.1.8 Interaction of Tensile and Shear Forces:** For designs that include combined tension and shear, the interaction of tension and shear loads must be calculated in accordance with ACI 318-14 Section 17.6 or ACI 318-11 Section D.7, as applicable.

**4.1.9 Minimum Member Thickness,  $h_{min}$ , Anchor Spacing,  $s_{min}$  and Edge Distance,  $c_{min}$ :** In lieu of ACI 318-14 17.7.1 and 17.7.3; or ACI 318-11 D.8.1 and D.8.3, as applicable, values of  $s_{min}$  and  $c_{min}$  described in this report

must be observed for anchor design and installation. Likewise, in lieu of ACI 318-14 17.7.5 or ACI 318-11 D.8.5, as applicable, the minimum member thicknesses,  $h_{min}$ , described in this report must be observed for anchor design and installation. For adhesive anchors that will remain untorqued, ACI 318-14 17.7.4 or ACI 318-11 D.8.4, as applicable, applies.

For edge distances  $c_{ai}$  and anchor spacing  $s_{ai}$ , the maximum torque  $T_{max}$  shall comply with the following requirements:

REDUCED MAXIMUM INSTALLATION TORQUE $T_{max,red}$ FOR EDGE DISTANCES $c_{ai} < (5 \times d_a)$		
EDGE DISTANCE, $c_{ai}$	MINIMUM ANCHOR SPACING, $s_{ai}$	MAXIMUM TORQUE, $T_{max,red}$
1.75 in. (45 mm) $\leq c_{ai} < 5 \times d_a$	$5 \times d_a \leq s_{ai} < 16$ in.	$0.3 \times T_{max}$
	$s_{ai} \geq 16$ in. (406 mm)	$0.5 \times T_{max}$

**4.1.10 Critical Edge Distance  $c_{ac}$  and  $\psi_{cp,Na}$ :** The modification factor  $\psi_{cp,Na}$ , must be determined in accordance with ACI 318-14 17.4.5.5 or ACI 318-11 D.5.5.5, as applicable, except as noted below:

For all cases where  $c_{Na}/c_{ac} < 1.0$ ,  $\psi_{cp,Na}$  determined from ACI 318-14 Eq. 17.4.5.5b or ACI 318-11 Eq. D-27, as applicable, need not be taken less than  $c_{Na}/c_{ac}$ . For all other cases,  $\psi_{cp,Na}$  shall be taken as 1.0.

The critical edge distance,  $c_{ac}$  must be calculated according to Eq. 17.4.5.5c for ACI 318-14 or Eq. D-27a for ACI 318-11, in lieu of ACI 318-14 17.7.6 or ACI 318-11 D.8.6, as applicable.

$$c_{ac} = h_{ef} \left( \frac{\tau_{k,uncr}}{1160} \right)^{0.4} \cdot \left[ 3.1 - 0.7 \frac{h}{h_{ef}} \right]$$

(Eq. 17.4.5.5c for ACI 318-14 or Eq. D-27a for ACI 318-11)

where

$\left[ \frac{h}{h_{ef}} \right]$  need not be taken as larger than 2.4; and

$\tau_{k,uncr}$  = the characteristic bond strength stated in the tables of this report whereby  $\tau_{k,uncr}$  need not be taken as larger than:

$$\tau_{k,uncr} = \frac{k_{uncr} \sqrt{h_{ef} f'_c}}{\pi \cdot d_a} \tag{Eq. 4-1}$$

**4.1.11 Design Strength in Seismic Design Categories C, D, E and F:** In structures assigned to Seismic Design Category C, D, E or F under the IBC or IRC, the design must be performed according to ACI 318-14 17.2.3 or ACI 318-11 Section D.3.3, as applicable. Modifications to ACI 318-14 17.2.3 shall be applied under Section 1905.1.8 of the 2018 and 2015 IBC. For the 2012 IBC, Section 1905.1.9 shall be omitted. Modifications to ACI 318-08 D.3.3 must be applied under Section 1908.1.9 of the 2009 IBC.

The nominal steel shear strength,  $V_{sa}$ , must be adjusted by  $\alpha_{V,seis}$  as given in the tables summarized in Table 1 for the anchor element types included in this report. For tension, the nominal pullout strength  $N_{p,cr}$  or bond strength  $\tau_{cr}$  must be adjusted by  $\alpha_{N,seis}$ .

Modify ACI 318-11 Sections D.3.3.4.2, D.3.3.4.3(d) and D.3.3.5.2 to read as follows:

ACI 318-11 D.3.3.4.2 - Where the tensile component of the strength-level earthquake force applied to anchors exceeds 20 percent of the total factored anchor tensile force

See Tables 7, 8, 11, 12 and 15.

喜利得股份有限公司

送審專用

FOR REVIEW

associated with the same load combination, anchors and their attachments shall be designed in accordance with ACI 318-11 D.3.3.4.3. The anchor design tensile strength shall be determined in accordance with ACI 318-11 D.3.3.4.4

**Exception:**

1. Anchors designed to resist wall out-of-plane forces with design strengths equal to or greater than the force determined in accordance with ASCE 7 Equation 12.11-1 or 12.14-10 shall be deemed to satisfy ACI 318-11 D.3.3.4.3(d).

ACI 318-11 D.3.3.4.3(d) – The anchor or group of anchors shall be designed for the maximum tension obtained from design load combinations that include E, with E increased by  $\Omega_0$ . The anchor design tensile strength shall be calculated from ACI 318-11 D.3.3.4.4.

ACI 318-11 D.3.3.5.2 – Where the shear component of the strength-level earthquake force applied to anchors exceeds 20 percent of the total factored anchor shear force associated with the same load combination, anchors and their attachments shall be designed in accordance with ACI 318-11 D.3.3.5.3. The anchor design shear strength for resisting earthquake forces shall be determined in accordance with ACI 318-11 D.6.

**Exceptions:**

1. For the calculation of the in-plane shear strength of anchor bolts attaching wood sill plates of bearing or non-bearing walls of light-frame wood structures to foundations or foundation stem walls, the in-plane shear strength in accordance with ACI 318-11 D.6.2 and D.6.3 need not be computed and ACI 318-11 D.3.3.5.3 need not apply provided all of the following are satisfied:

- 1.1. The allowable in-plane shear strength of the anchor is determined in accordance with AF&PA NDS Table 11E for lateral design values parallel to grain.
- 1.2. The maximum anchor nominal diameter is  $5/8$  inch (16 mm).
- 1.3. Anchor bolts are embedded into concrete a minimum of 7 inches (178 mm).
- 1.4. Anchor bolts are located a minimum of  $1\ 3/4$  inches (45 mm) from the edge of the concrete parallel to the length of the wood sill plate.
- 1.5. Anchor bolts are located a minimum of 15 anchor diameters from the edge of the concrete perpendicular to the length of the wood sill plate.
- 1.6. The sill plate is 2-inch or 3-inch nominal thickness.

2. For the calculation of the in-plane shear strength of anchor bolts attaching cold-formed steel track of bearing or non-bearing walls of light-frame construction to foundations or foundation stem walls, the in-plane shear strength in accordance with ACI 318-11 D.6.2 and D.6.3, need not be computed and ACI 318-11 D.3.3.5.3 need not apply provided all of the following are satisfied:

- 2.1. The maximum anchor nominal diameter is  $5/8$  inch (16 mm).
- 2.2. Anchors are embedded into concrete a minimum of 7 inches (178 mm).
- 2.3. Anchors are located a minimum of  $1\ 3/4$  inches (45 mm) from the edge of the concrete parallel to the length of the track.
- 2.4. Anchors are located a minimum of 15 anchor diameters from the edge of the concrete perpendicular to the length of the track.

2.5. The track is 33 to 68 mil designation thickness.

Allowable in-plane shear strength of exempt anchors, parallel to the edge of concrete shall be permitted to be determined in accordance with AISI S100 Section E3.3.1.

3. In light-frame construction, bearing or nonbearing walls, shear strength of concrete anchors less than or equal to 1 inch [25 mm] in diameter attaching a sill plate or track to foundation or foundation stem wall need not satisfy ACI 318-11 D.3.3.5.3(a) through (c) when the design strength of the anchors is determined in accordance with ACI 318-11 D.6.2.1(c).

**4.2 Strength Design of Post-Installed Reinforcing Bars:**

**4.2.1 General:** The design of straight post-installed deformed reinforcing bars must be determined in accordance with ACI 318 rules for cast-in place reinforcing bar development and splices and this report.

Examples of typical applications for the use of post-installed reinforcing bars are illustrated in Figures 2 and 3 of this report. A design example in accordance with the 2018 and 2015 IBC based on ACI 318-14 is given in Figure 8 of this report.

**4.2.2 Determination of bar development length  $l_d$ :** Values of  $l_d$  must be determined in accordance with the ACI 318 development and splice length requirements for straight cast-in place reinforcing bars.

**Exceptions:**

- 1. For uncoated and zinc-coated (galvanized) post-installed reinforcing bars, the factor  $\Psi_e$  shall be taken as 1.0. For all other cases, the requirements in ACI 318-14 25.4.2.4 or ACI 318-11 12.2.4 (b) shall apply.
- 2. When using alternate methods to calculate the development length (e.g., anchor theory), the applicable factors for post-installed anchors generally apply.

**4.2.3 Minimum Member Thickness,  $h_{min}$ , Minimum Concrete Cover,  $c_{c,min}$ , Minimum Concrete Edge Distance,  $c_{b,min}$ , Minimum Spacing,  $s_{b,min}$ :** For post-installed reinforcing bars, there is no limit on the minimum member thickness. In general, requirements on concrete cover and spacing applicable to straight cast-in bars designed in accordance with ACI 318 shall be maintained.

For post-installed reinforcing bars installed at embedment depths,  $h_{ef}$ , larger than 20d ( $h_{ef} > 20d$ ), the minimum concrete cover shall be as follows:

REBAR SIZE	MINIMUM CONCRETE COVER, $c_{c,min}$
$d_b \leq$ No. 6 (16 mm)	$1\ 3/16$ in. (30mm)
No. 6 < $d_b \leq$ No. 10 (16mm < $d_b \leq$ 32mm)	$1\ 9/16$ in. (40mm)

The following requirements apply for minimum concrete edge and spacing for  $h_{ef} > 20d$ :

Required minimum edge distance for post-installed reinforcing bars (measured from the center of the bar):

$$c_{b,min} = d_o/2 + c_{c,min}$$

Required minimum center-to-center spacing between post-installed bars:

$$s_{b,min} = d_o + c_{c,min}$$

Required minimum center-to-center spacing from existing (parallel) reinforcing:

$$s_{b,min} = d_b/2 \text{ (existing reinforcing)} + d_o/2 + c_{c,min}$$

喜利得股份有限公司

送審專用

FOR REVIEW



All other requirements applicable to straight cast-in place bars designed in accordance with ACI 318 shall be maintained.

**4.2.4 Design Strength in Seismic Design Categories C, D, E and F:** In structures assigned to Seismic Category C, D, E or F under the IBC or IRC, design of straight post-installed reinforcing bars must take into account the provisions of ACI 318-14 Chapter 18 or ACI 318-11 Chapter 21, as applicable. The value of  $f_c$  to be used in calculations per ACI 318-14 25.4.2.2, 25.4.2.3, and 25.4.9.2, or ACI 318-11 Section 12.2.2, 12.2.3, and 12.3.2, as applicable, shall not exceed 2,500 psi.

#### 4.3 Installation:

Installation parameters are illustrated in Figure 1. Installation must be in accordance with ACI 318-14 17.8.1 and 17.8.2; or ACI 318-11 D.9.1 and D.9.2, as applicable. Anchor and post-installed reinforcing bar locations must comply with this report and the plans and specifications approved by the code official. Installation of the Hilti HIT-RE 100 Adhesive Anchor and Post-Installed Reinforcing Bar Systems must conform to the manufacturer's printed installation instructions (MPII) included in each unit package as provided in Figure 9 of this report. The MPII contains additional requirements for combinations of drill hole depth, diameter, and dispensing and installation equipment.

The initial cure time,  $t_{cure,ini}$ , as noted in Figure 9 of this report, is intended for rebar applications only and is the time where rebar and concrete formwork preparation may continue. Between the initial cure time and the full cure time,  $t_{cure,final}$ , the adhesive has a limited load bearing capacity. Do not apply a torque or load on the rebar during this time.

#### 4.4 Special Inspection:

Periodic special inspection must be performed where required in accordance with Section 1705.1.1 and Table 1705.3 of the 2018 and 2015 and 2012 IBC, or Section 1704.15 and Table 1704.4 of the 2009 IBC, and this report. The special inspector must be on the jobsite initially during anchor and post-installed reinforcing bar installation to verify anchor and post-installed reinforcing bar type and dimensions, concrete type, concrete compressive strength, adhesive identification and expiration date, hole dimensions, hole cleaning procedures, spacing, edge distances, concrete thickness, anchor and post-installed reinforcing bars embedment, tightening torque and adherence to the manufacturer's printed installation instructions.

The special inspector must verify the initial installations of each type and size of adhesive anchor and post-installed reinforcing bar by construction personnel on site. Subsequent installations of the same anchor and post-installed reinforcing bar type and size by the same construction personnel are permitted to be performed in the absence of the special inspector. Any change in the anchor and post-installed reinforcing bar product being installed or the personnel performing the installation requires an initial inspection. For ongoing installations over an extended period, the special inspector must make regular inspections to confirm correct handling and installation of the product.

Continuous special inspection of adhesive anchors and post-installed reinforcing bars installed in horizontal or upwardly inclined orientations to resist sustained tension loads shall be performed in accordance with ACI 318-14 17.8.2.4, 26.7.1(h), and 26.13.3.2(c); or ACI 318-11 D.9.2.4, as applicable.

Under the IBC, additional requirements as set forth in Sections 1705, 1706, and 1707 must be observed, where applicable.

## 5.0 CONDITIONS OF USE

The Hilti HIT-RE 100 Adhesive Anchor System and Post-Installed Reinforcing Bars described in this report complies with or is a suitable alternative to what is specified in the codes listed in Section 1.0 of this report, subject to the following conditions:

- 5.1 Hilti HIT-RE 100 Adhesive anchors and post-installed reinforcing bars must be installed in accordance with the manufacturer's printed installation instructions as included in the adhesive packaging and provided in Figure 5 of this report.
- 5.2 The anchors and post-installed reinforcing bars must be installed in cracked and uncracked normal-weight concrete having a specified compressive strength  $f_c = 2,500$  psi to 8,500 psi (17.2 MPa to 58.6 MPa).
- 5.3 The values of  $f_c$  used for calculation purposes must not exceed 8,000 psi (55.1 MPa) except as noted in Section 4.2.4 of this report.
- 5.4 The concrete shall have attained its minimum compressive strength prior to the installation of anchors and post-installed reinforcing bars.
- 5.5 Anchors and post-installed reinforcing bars must be installed in concrete base materials in holes predrilled in accordance with the instructions in Figure 9, using carbide-tipped drill bits manufactured with the range of maximum and minimum drill-tip dimensions specified in ANSI B212.15-1994.
- 5.6 Loads applied to the anchors must be adjusted in accordance with Section 1605.2 of the IBC for strength design.
- 5.7 Hilti HIT-RE 100 adhesive anchors and post-installed reinforcing bars are recognized for use to resist short- and long-term loads, including wind and earthquake, subject to the conditions of this report.
- 5.8 In structures assigned to Seismic Design Category C, D, E or F under the IBC or IRC, anchor strength must be adjusted in accordance with Section 4.1.11 of this report and post-installed reinforcing bars must comply with section 4.2.4 of this report.
- 5.9 Hilti HIT-RE 100 adhesive anchors and post-installed reinforcing bars are permitted to be installed in concrete that is cracked or that may be expected to crack during the service life of the anchor, subject to the conditions of this report.
- 5.10 Anchor strength design values must be established in accordance with Section 4.1 of this report.
- 5.11 Post-installed reinforcing bar development and splice length is established in accordance with Section 4.2 of this report.
- 5.12 Minimum anchor spacing and edge distance as well as minimum member thickness must comply with the values noted in this report.
- 5.13 Prior to installation, calculations and details demonstrating compliance with this report must be submitted to the code official. The calculations and details must be prepared by a registered design professional where required by the statutes of the jurisdiction in which the project is to be constructed.
- 5.14 Anchors and post-installed reinforcing bars are not permitted to support fire-resistive construction. Where not otherwise prohibited by the code, Hilti HIT-RE 100 adhesive anchors are permitted for installation in fire-resistive construction provided that at least one of the following conditions is fulfilled:

喜利得股份有限公司  
送審專用  
FOR REVIEW

- Anchors and post-installed reinforcing bars are used to resist wind or seismic forces only.
  - Anchors and post-installed reinforcing bars that support gravity load-bearing structural elements are within a fire-resistive envelope or a fire-resistive membrane, are protected by approved fire-resistive materials, or have been evaluated for resistance to fire exposure in accordance with recognized standards.
  - Anchors and post-installed reinforcing bars are used to support nonstructural elements.
- 5.15** Since an ICC-ES acceptance criteria for evaluating data to determine the performance of adhesive anchors and post-installed reinforcing bars subjected to fatigue or shock loading is unavailable at this time, the use of these anchors under such conditions is beyond the scope of this report.
- 5.16** Use of zinc-plated carbon steel threaded rods or steel reinforcing bars is limited to dry, interior locations.
- 5.17** Use of hot-dipped galvanized carbon steel and stainless steel rods is permitted for exterior exposure or damp environments.
- 5.18** Steel anchoring materials in contact with preservative-treated and fire-retardant-treated wood must be of zinc-coated carbon steel or stainless steel. The minimum coating weights for zinc-coated steel must comply with ASTM A153.
- 5.19** Periodic special inspection must be provided in accordance with Section 4.4 of this report. Continuous special inspection for anchors and post-installed reinforcing bars installed in horizontal or upwardly inclined orientations to resist sustained tension loads must be provided in accordance with Section 4.4 of this report.
- 5.20** Installation of anchors and post-installed reinforcing bars in horizontal or upwardly inclined orientations to resist sustained tension loads shall be performed by personnel certified by an applicable certification program in accordance with ACI 318-14 17.8.2.2 or 17.8.2.3; or ACI 318-11 D.9.2.2 or D.9.2.3, as applicable.

**5.21** Hilti HIT-RE 100 adhesive anchors may be used to resist tension and shear forces in floor, wall, and overhead installations only if installation is into concrete with a temperature between 41°F and 104°F (5°C and 40°C) for threaded rods and rebar. Overhead installations for hole diameters larger than 7/16-inch or 10mm require the use of piston plugs (HIT-SZ) during injection to the back of the hole. 7/16-inch or 10mm diameter holes may be injected directly to the back of the hole with the use of extension tubing on the end of the nozzle. The adhesive anchor must be supported until fully cured (i.e., with Hilti HIT-OHW wedges, or other suitable means). Where temporary restraint devices are used, their use shall not result in impairment of the anchor shear resistance.

**5.22** Hilti HIT-RE 100 adhesive is manufactured by Hilti GmbH, Kaufering, Germany, under a quality-control program with inspections by ICC-ES.

**6.0 EVIDENCE SUBMITTED**

Data in accordance with the ICC-ES Acceptance Criteria for Post-installed Adhesive Anchors in Concrete (AC308), dated June 2019, which incorporates requirements in ACI 355.4-11, including but not limited to tests under freeze/thaw conditions (Table 3.2, test series 6); and quality-control documentation.

**7.0 IDENTIFICATION**

**7.1** Hilti HIT-RE 100 adhesive is identified by packaging labeled with the company name (Hilti) and address, product name, lot number, expiration date, and evaluation report number (ESR-3829).

**7.2** Threaded rods, nuts, washers, and deformed reinforcing bars are standard elements and must conform to applicable national or international specifications.

**7.3** The report holder’s contact information is the following:

**HILTI, INC.**  
**7250 DALLAS PARKWAY, SUITE 1000**  
**PLANO, TEXAS 75024**  
**(800) 879-8000**  
[www.us.hilti.com](http://www.us.hilti.com)  
[HiltiTechEng@us.hilti.com](mailto:HiltiTechEng@us.hilti.com)

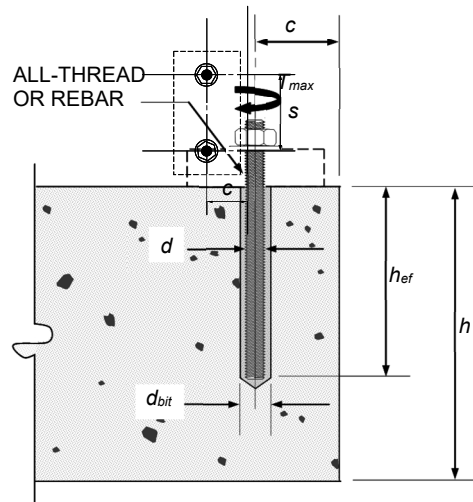

THREADED ROD/REINFORCING BAR

FIGURE 1—INSTALLATION PARAMETERS FOR POST-INSTALLED ADHESIVE ANCHORS

喜利得股份有限公司

送審專用

FOR REVIEW

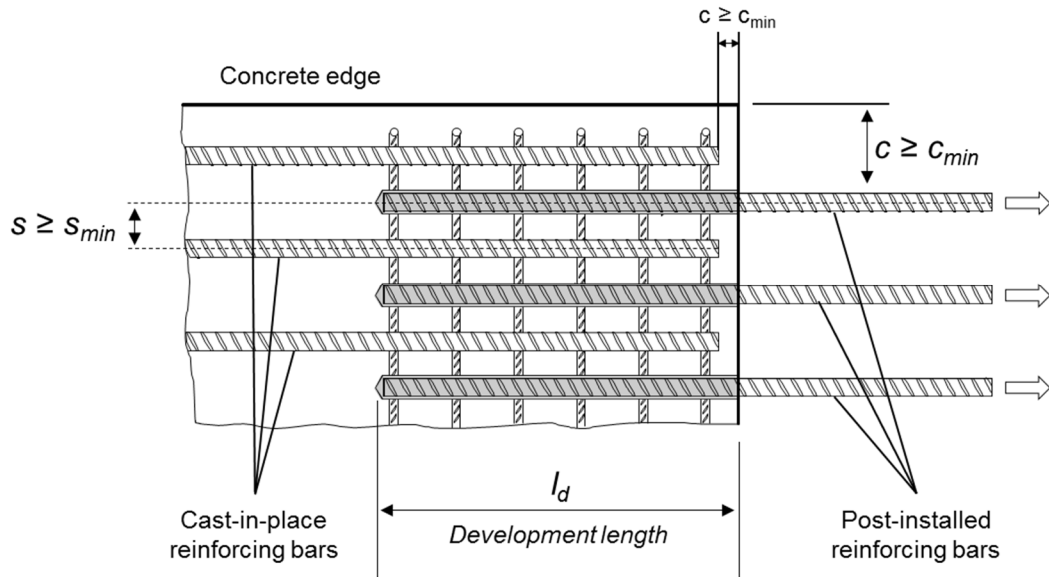

FIGURE 2—INSTALLATION PARAMETERS FOR POST-INSTALLED REINFORCING BARS

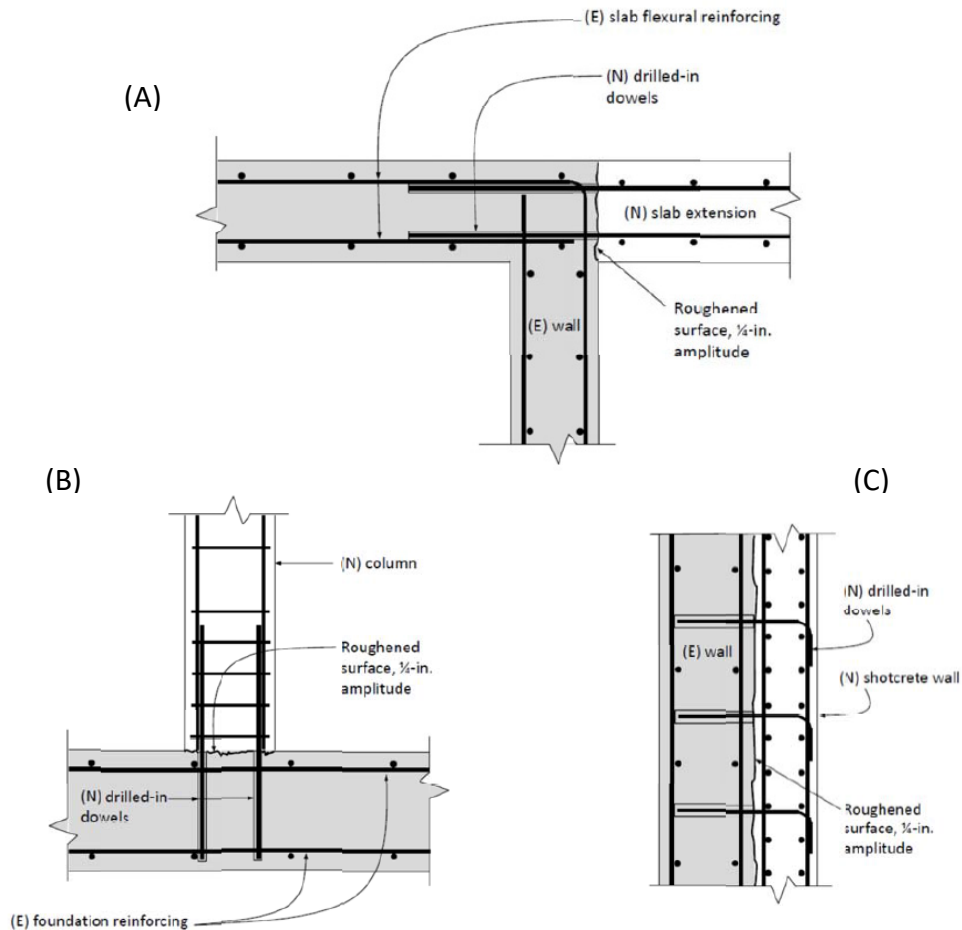

FIGURE 3—(A) TENSION LAP SPLICE WITH EXISTING FLEXURAL REINFORCEMENT; (B) TENSION DEVELOPMENT OF COLUMN DOWELS; (C) DEVELOPMENT OF SHEAR DOWELS FOR NEW ONLAY SHEAR WALL

喜利得股份有限公司

送審專用

FOR REVIEW

**DEFORMED REINFORCEMENT**

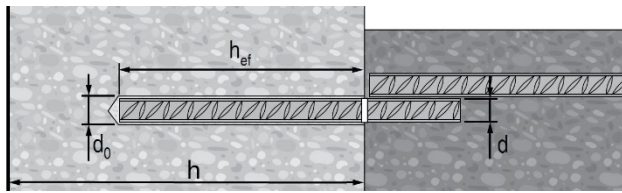

**US Rebar**

d	Ø d <sub>0</sub> [inch]	h <sub>ef</sub> [inch]
# 3	1/2	2 3/8...22 1/2
# 4	5/8	2 3/4...30
# 5	3/4	3 1/8...37 1/2
	7/8	3 1/2...15
# 6	1	15...45
	1 1/8	17 1/2...52 1/2
# 7	1 1/8	4...20
	1 1/4	20...60
# 8	1 3/8	4 1/2...67 1/2
# 9	1 1/2	5...75
# 10	1 3/4	5 1/2...82 1/2

**CA Rebar**

d	Ø d <sub>0</sub> [inch]	h <sub>ef</sub> [mm]
10 M	3/16	70...678
15 M	3/4	80...960
20 M	1	90...1170
25 M	1 1/4 (32 mm)	101...1512
30 M	1 1/2	120...1794

**EU Rebar**

Ø d [mm]	Ø d <sub>0</sub> [mm]	h <sub>ef</sub> [mm]
8	12	60...480
10	14	60...600
12	16	70...720
14	18	75...840
16	20	80...960
18	22	85...1080
20	25	90...1200
22	28	95...1320
24	32	96...1440
25	32	100...1500
26	35	104...1560
28	35	112...1680
30	37	120...1800
32	40	128...1920

**THREADED ROD**

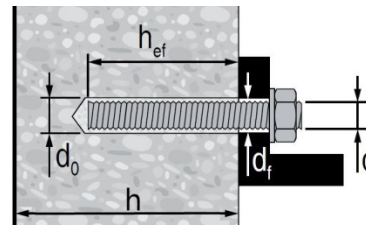

**HAS / HIT-V**

Ø d [inch]	Ø d <sub>0</sub> [inch]	h <sub>ef</sub> [inch]	Ø d <sub>f</sub> [inch]	T <sub>max</sub> [ft-lb]	T <sub>max</sub> [Nm]
3/8	7/16	2 3/8... 7 1/2	7/16	15	20
1/2	9/16	2 3/4... 10	9/16	30	41
5/8	3/4	3 1/8... 12 1/2	11/16	60	81
3/4	7/8	3 1/2... 15	13/16	100	136
7/8	1	3 1/2... 17 1/2	15/16	125	169
1	1 1/8	4... 20	1 1/8	150	203
1 1/4	1 3/8	5... 25	1 3/8	200	271

**HIT-V**

Ø d [mm]	Ø d <sub>0</sub> [mm]	h <sub>ef</sub> [mm]	Ø d <sub>f</sub> [mm]	T <sub>max</sub> [Nm]
M8	10	60...160	9	10
M10	12	60...200	12	20
M12	14	70...240	14	40
M16	18	80...320	18	80
M20	22	90...400	22	150
M24	28	96...480	26	200
M27	30	108...540	30	270
M30	35	120...600	33	300

**FIGURE 4—INSTALLATION PARAMETERS**

喜利得股份有限公司  
 送審專用  
 FOR REVIEW

TABLE 1—DESIGN TABLE INDEX

Design Table		Fractional		Metric	
		Table	Page	Table	Page
 Standard Threaded Rod	Steel Strength - $N_{sa}, V_{sa}$	4	11	9	16
	Concrete Breakout - $N_{cb}, N_{cbg}, V_{cb}, V_{cbg}, V_{cp}, V_{cpq}$	6	13	10	17
	Bond Strength - $N_a, N_{ag}$	8	15	12	19

Design Table		Fractional		EU Metric		Canadian	
		Table	Page	Table	Page	Table	Page
 Steel Reinforcing Bars	Steel Strength - $N_{sa}, V_{sa}$	5	12	9	16	13	20
	Concrete Breakout - $N_{cb}, N_{cbg}, V_{cb}, V_{cbg}, V_{cp}, V_{cpq}$	6	13	10	17	14	20
	Bond Strength - $N_a, N_{ag}$	7	14	11	18	15	21
	Determination of development length for post-installed reinforcing bar connections	16	22	17	22	18	23

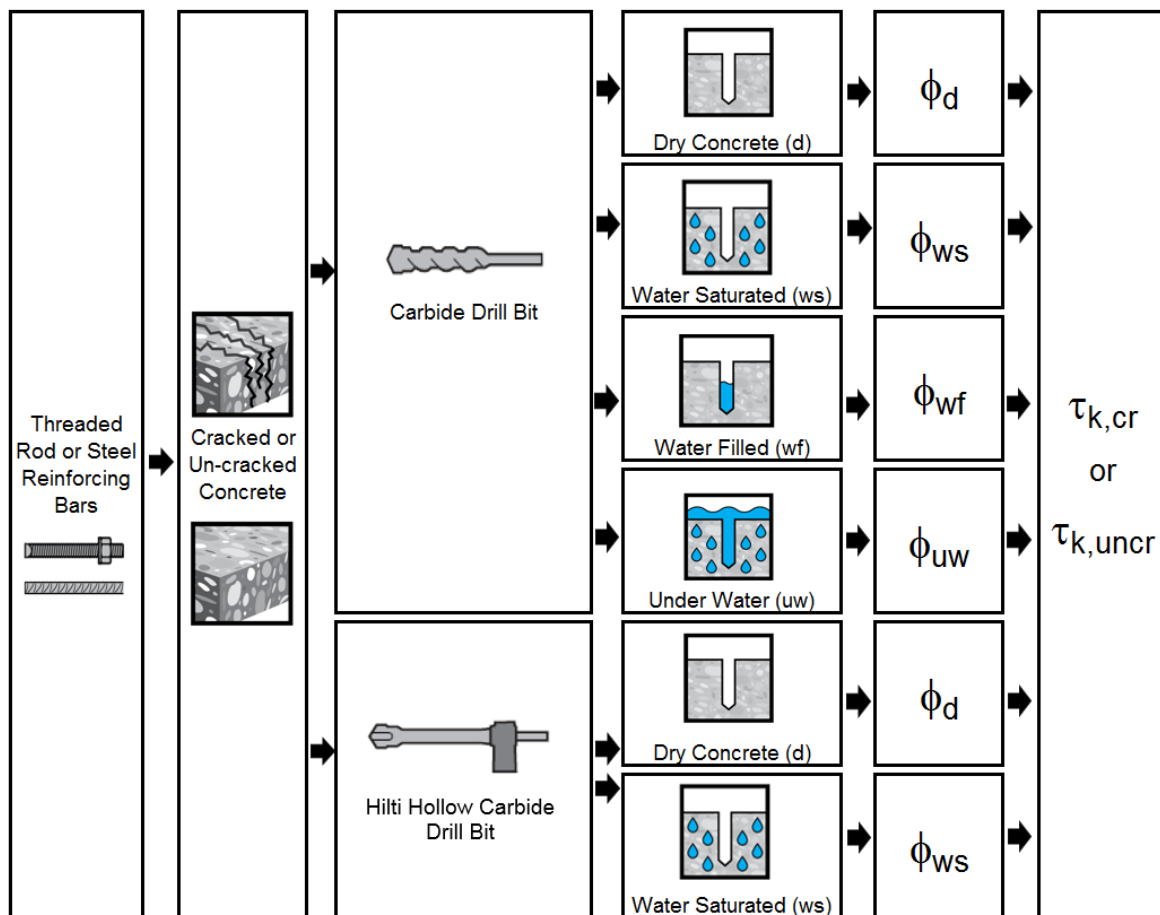

FIGURE 5—FLOWCHART FOR THE ESTABLISHMENT OF DESIGN BOND STRENGTH

喜利得股份有限公司

送審專用

FOR REVIEW

**TABLE 2—SPECIFICATIONS AND PHYSICAL PROPERTIES OF COMMON CARBON AND STAINLESS STEEL THREADED ROD MATERIALS<sup>1</sup>**

THREADED ROD SPECIFICATION			Minimum specified ultimate strength, $f_{uta}$	Minimum specified yield strength 0.2 percent offset, $f_{ya}$	$f_{uta}/f_{ya}$	Elongation, min. percent <sup>6</sup>	Reduction of Area, min. percent	Specification for nuts <sup>8</sup>
CARBON STEEL	ASTM A193 <sup>2</sup> Grade B7 ≤ 2 1/2 in. (≤ 64 mm)	psi (MPa)	125,000 (862)	105,000 (724)	1.19	16	50	ASTM A194
	ASTM F1554, Grade 36 <sup>6</sup>	psi (MPa)	58,000 (400)	36,000 (248)	1.61	23	40	ASTM A194 or ASTM A563
	ASTM F1554, Grade 55 <sup>6</sup>	psi (MPa)	75,000 (517)	55,000 (379)	1.36	21	30	ASTM A194 or ASTM A563
	ASTM F1554, Grade 105 <sup>6</sup>	psi (MPa)	125,000 (862)	105,000 (724)	1.19	15	45	ASTM A194 or ASTM A563
	ISO 898-1 <sup>3</sup> Class 5.8	MPa (psi)	500 (72,500)	400 (58,000)	1.25	22	-	DIN 934 Grade 6
	ISO 898-1 <sup>3</sup> Class 8.8	MPa (psi)	800 (116,000)	640 (92,800)	1.25	12	52	DIN 934 Grade 8
STAINLESS STEEL	ASTM F593 <sup>4</sup> CW1 (316) 1/4-in. to 5/8-in.	psi (MPa)	100,000 (690)	65,000 (448)	1.54	20	-	ASTM F594
	ASTM F593 <sup>4</sup> CW2 (316) 3/4-in. to 1 1/2-in.	psi (MPa)	85,000 (586)	45,000 (310)	1.89	25	-	ASTM F594
	ASTM A193 Grade 8(M), Class 1 <sup>2</sup> 1 1/4-in.	psi (MPa)	75,000 (517)	30,000 (207)	2.50	30	50	ASTM A194
	ISO 3506-1 <sup>5</sup> A4-70 M8 – M24	MPa (psi)	700 (101,500)	450 (65,250)	1.56	40	-	ISO 4032
	ISO 3506-1 <sup>5</sup> A4-50 M27 – M30	MPa (psi)	500 (72,500)	210 (30,450)	2.38	40	-	ISO 4032

<sup>1</sup>Hilti HIT-RE 100 adhesive may be used in conjunction with all grades of continuously threaded carbon or stainless steel rod (all-thread) that comply with the code reference standards and that have thread characteristics comparable with ANSI B1.1 UNC Coarse Thread Series or ANSI B1.13M M Profile Metric Thread Series.

Values for threaded rod types and associated nuts supplied by Hilti are provided here.

<sup>2</sup>Standard Specification for Alloy-Steel and Stainless Steel Bolting Materials for High-Temperature Service

<sup>3</sup>Mechanical properties of fasteners made of carbon steel and alloy steel – Part 1: Bolts, screws and studs

<sup>4</sup>Standard Steel Specification for Stainless Steel Bolts, Hex Cap Screws, and Studs

<sup>5</sup>Mechanical properties of corrosion-resistant stainless steel fasteners – Part 1: Bolts, screws and studs

<sup>6</sup>Standard Specification for Anchor Bolts, Steel, 36, 55, and 105-ksi Yield Strength

<sup>7</sup>Based on 2-in. (50 mm) gauge length except for A 193, which are based on a gauge length of 4d and ISO 898, which is based on 5d.

<sup>8</sup>Nuts of other grades and styles having specified proof load stresses greater than the specified grade and style are also suitable. Nuts must have specified proof load stresses equal to or greater than the minimum tensile strength of the specified threaded rod.

**TABLE 3—SPECIFICATIONS AND PHYSICAL PROPERTIES OF COMMON STEEL REINFORCING BARS**

REINFORCING BAR SPECIFICATION		Minimum specified ultimate strength, $f_{uta}$	Minimum specified yield strength, $f_{ya}$
ASTM A615 <sup>1</sup> Gr. 60	psi (MPa)	90,000 (620)	60,000 (414)
ASTM A615 <sup>1</sup> Gr. 40	psi (MPa)	60,000 (414)	40,000 (276)
ASTM A706 <sup>2</sup> Gr. 60	psi (MPa)	80,000 (550)	60,000 (414)
DIN 488 <sup>3</sup> BSt 500	MPa (psi)	550 (79,750)	500 (72,500)
CAN/CSA-G30.18 <sup>4</sup> Gr. 400	MPa (psi)	540 (78,300)	400 (58,000)

<sup>1</sup>Standard Specification for Deformed and Plain Carbon Steel Bars for Concrete Reinforcement

<sup>2</sup>Standard Specification for Low Alloy Steel Deformed and Plain Bars for Concrete Reinforcement

<sup>3</sup>Reinforcing steel; reinforcing steel bars; dimensions and masses

<sup>4</sup>Billet-Steel Bars for Concrete Reinforcement

喜利得股份有限公司  
(58,000)

送審專用

FOR REVIEW

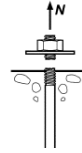

Fractional Threaded Rod

Steel Strength

TABLE 4—STEEL DESIGN INFORMATION FOR FRACTIONAL THREADED ROD

DESIGN INFORMATION		Symbol	Units	Nominal rod diameter (in.) <sup>1</sup>						
				3/8	1/2	5/8	3/4	7/8	1	1 1/4
Rod outside diameter		<i>d</i>	in. (mm)	0.375 (9.5)	0.5 (12.7)	0.625 (15.9)	0.75 (19.1)	0.875 (22.2)	1 (25.4)	1.25 (31.8)
Rod effective cross-sectional area		<i>A<sub>se</sub></i>	in. <sup>2</sup> (mm <sup>2</sup> )	0.0775 (50)	0.1419 (92)	0.2260 (146)	0.3345 (216)	0.4617 (298)	0.6057 (391)	0.9691 (625)
ISO 898-1 Class 5.8	Nominal strength as governed by steel strength	<i>N<sub>sa</sub></i>	lb (kN)	5,620 (25.0)	10,290 (45.8)	16,385 (72.9)	24,250 (107.9)	33,470 (148.9)	43,910 (195.3)	70,260 (312.5)
		<i>V<sub>sa</sub></i>	lb (kN)	3,370 (15)	6,175 (27.5)	9,830 (43.7)	14,550 (64.7)	20,085 (89.3)	26,345 (117.2)	42,155 (187.5)
	Reduction for seismic shear	<i>α<sub>V,seis</sub></i>	-	0.70						
	Strength reduction factor for tension <sup>2</sup>	<i>φ</i>	-	0.65						
	Strength reduction factor for shear <sup>2</sup>	<i>φ</i>	-	0.60						
ASTM A193 B7	Nominal strength as governed by steel strength	<i>N<sub>sa</sub></i>	lb (kN)	9,685 (43.1)	17,735 (78.9)	28,250 (125.7)	41,810 (186.0)	57,710 (256.7)	75,710 (336.8)	121,135 (538.8)
		<i>V<sub>sa</sub></i>	lb (kN)	5,810 (25.9)	10,640 (47.3)	16,950 (75.4)	25,085 (111.6)	34,625 (154.0)	45,425 (202.1)	72,680 (323.3)
	Reduction for seismic shear	<i>α<sub>V,seis</sub></i>	-	0.70						
	Strength reduction factor for tension <sup>3</sup>	<i>φ</i>	-	0.75						
	Strength reduction factor for shear <sup>3</sup>	<i>φ</i>	-	0.65						
ASTM F1554 Gr. 36	Nominal strength as governed by steel strength	<i>N<sub>sa</sub></i>	lb (kN)	- (-)	8,230 (36.6)	13,110 (58.3)	19,400 (86.3)	26,780 (119.1)	35,130 (156.3)	56,210 (250.0)
		<i>V<sub>sa</sub></i>	lb (kN)	- (-)	4,940 (22.0)	7,865 (35.0)	11,640 (51.8)	16,070 (71.5)	21,080 (93.8)	33,725 (150.0)
	Reduction for seismic shear	<i>α<sub>V,seis</sub></i>	-	0.60						
	Strength reduction factor for tension <sup>3</sup>	<i>φ</i>	-	0.75						
	Strength reduction factor for shear <sup>3</sup>	<i>φ</i>	-	0.65						
ASTM F1554 Gr. 55	Nominal strength as governed by steel strength	<i>N<sub>sa</sub></i>	lb (kN)	- (-)	10,645 (47.4)	16,950 (75.4)	25,090 (111.6)	34,630 (154.0)	45,430 (202.1)	72,685 (323.3)
		<i>V<sub>sa</sub></i>	lb (kN)	- (-)	6,385 (28.4)	10,170 (45.2)	15,055 (67.0)	20,780 (92.4)	27,260 (121.3)	43,610 (194.0)
	Reduction for seismic shear	<i>α<sub>V,seis</sub></i>	-	0.70						
	Strength reduction factor for tension <sup>3</sup>	<i>φ</i>	-	0.75						
	Strength reduction factor for shear <sup>3</sup>	<i>φ</i>	-	0.65						
ASTM F1554 Gr. 105	Nominal strength as governed by steel strength	<i>N<sub>sa</sub></i>	lb (kN)	- (-)	17,740 (78.9)	28,250 (125.7)	41,815 (186.0)	57,715 (256.7)	75,715 (336.8)	121,135 (538.8)
		<i>V<sub>sa</sub></i>	lb (kN)	- (-)	10,645 (47.4)	16,950 (75.4)	25,090 (111.6)	34,630 (154.0)	45,430 (202.1)	72,680 (323.3)
	Reduction for seismic shear	<i>α<sub>V,seis</sub></i>	-	0.70						
	Strength reduction factor for tension <sup>3</sup>	<i>φ</i>	-	0.75						
	Strength reduction factor for shear <sup>3</sup>	<i>φ</i>	-	0.65						
ASTM F593, CW Stainless	Nominal strength as governed by steel strength	<i>N<sub>sa</sub></i>	lb (kN)	7,750 (34.5)	14,190 (63.1)	22,600 (100.5)	28,435 (126.5)	39,245 (174.6)	51,485 (229.0)	- (-)
		<i>V<sub>sa</sub></i>	lb (kN)	4,650 (20.7)	8,515 (37.9)	13,560 (60.3)	17,060 (75.9)	23,545 (104.7)	30,890 (137.4)	- (-)
	Reduction for seismic shear	<i>α<sub>V,seis</sub></i>	-	0.70						
	Strength reduction factor for tension <sup>2</sup>	<i>φ</i>	-	0.65						
	Strength reduction factor for shear <sup>2</sup>	<i>φ</i>	-	0.60						
ASTM A193 Gr. 8(M), Class 1 Stainless	Nominal strength as governed by steel strength	<i>N<sub>sa</sub></i>	lb (kN)	-	-	-	-	-	-	55,240 (245.7)
		<i>V<sub>sa</sub></i>	lb (kN)	-	-	-	-	-	-	33,145 (147.4)
	Reduction for seismic shear	<i>α<sub>V,seis</sub></i>	-	0.60						
	Strength reduction factor for tension <sup>3</sup>	<i>φ</i>	-	0.75						
	Strength reduction factor for shear <sup>3</sup>	<i>φ</i>	-	-						

For **SI**: 1 inch = 25.4 mm, 1 lbf = 4.448 N. For **pound-inch** units: 1 mm = 0.03937 inches, 1 N = 0.2248 lbf

<sup>1</sup>Values provided for common rod material types are based on specified strengths and calculated in accordance with ACI 318-14 Eq. (17.4.1.2) and Eq. (17.5.1.2b) or ACI 318-11 Eq. (D-2) and Eq. (D-29), as applicable. Nuts and washers must be appropriate for the rod.

<sup>2</sup>For use with the load combinations of IBC Section 1605.2, ACI 318-14 5.3 or ACI 318-11 9.2, as applicable, as set forth in ACI 318-14 17.3.3 or ACI 318-11 D.4.3, as applicable. If the load combinations of ACI 318-11 Appendix C are used, the appropriate value of *φ* must be determined in accordance with ACI 318-11 D.4.4. Values correspond to a brittle steel element.

<sup>3</sup>For use with the load combinations of IBC Section 1605.2, ACI 318-14 5.3 or ACI 318-11 9.2, as applicable, as set forth in ACI 318-14 17.3.3 or ACI 318-11 D.4.3, as applicable. If the load combinations of ACI 318-11 Appendix C are used, the appropriate value of *φ* must be determined in accordance with ACI 318-11 D.4.4. Values correspond to a ductile steel element.

喜利得股份有限公司

送審專用

FOR REVIEW



Fractional Reinforcing Bars

Steel Strength

TABLE 5—STEEL DESIGN INFORMATION FOR FRACTIONAL REINFORCING BARS

DESIGN INFORMATION		Symbol	Units	Nominal Reinforcing bar size (Rebar)							
				#3	#4	#5	#6	#7	#8	#9	#10
Nominal bar diameter		$d$	in. (mm)	<sup>3</sup> / <sub>8</sub> (9.5)	<sup>1</sup> / <sub>2</sub> (12.7)	<sup>5</sup> / <sub>8</sub> (15.9)	<sup>3</sup> / <sub>4</sub> (19.1)	<sup>7</sup> / <sub>8</sub> (22.2)	1 (25.4)	<sup>1</sup> / <sub>8</sub> (28.6)	<sup>1</sup> / <sub>4</sub> (31.8)
Bar effective cross-sectional area		$A_{se}$	in. <sup>2</sup> (mm <sup>2</sup> )	0.11 (71)	0.2 (129)	0.31 (200)	0.44 (284)	0.6 (387)	0.79 (510)	1.0 (645)	1.27 (819)
ASTM A615 Grade 40	Nominal strength as governed by steel strength	$N_{sa}$	lb (kN)	6,600 (29.4)	12,000 (53.4)	18,600 (82.7)	26,400 (117.4)	36,000 (160.1)	47,400 (210.9)	60,000 (266.9)	76,200 (339.0)
		$V_{sa}$	lb (kN)	3,960 (17.6)	7,200 (32.0)	11,160 (49.6)	15,840 (70.5)	21,600 (96.1)	28,440 (126.5)	36,000 (160.1)	45,720 (203.4)
	Reduction for seismic shear	$\alpha_{V,seis}$	-	0.70							
	Strength reduction factor $\phi$ for tension <sup>2</sup>	$\phi$	-	0.65							
	Strength reduction factor $\phi$ for shear <sup>2</sup>	$\phi$	-	0.60							
ASTM A615 Grade 60	Nominal strength as governed by steel strength	$N_{sa}$	lb (kN)	9,900 (44.0)	18,000 (80.1)	27,900 (124.1)	39,600 (176.2)	54,000 (240.2)	71,100 (316.3)	90,000 (400.4)	114,300 (508.5)
		$V_{sa}$	lb (kN)	5,940 (26.4)	10,800 (48.0)	16,740 (74.5)	23,760 (105.7)	32,400 (144.1)	42,660 (189.8)	54,000 (240.2)	68,580 (305.1)
	Reduction for seismic shear	$\alpha_{V,seis}$	-	0.70							
	Strength reduction factor $\phi$ for tension <sup>2</sup>	$\phi$	-	0.65							
	Strength reduction factor $\phi$ for shear <sup>2</sup>	$\phi$	-	0.60							
ASTM A706 Grade 60	Nominal strength as governed by steel strength	$N_{sa}$	lb (kN)	8,800 (39.1)	16,000 (71.2)	24,800 (110.3)	35,200 (156.6)	48,000 (213.5)	63,200 (281.1)	80,000 (355.9)	101,600 (452.0)
		$V_{sa}$	lb (kN)	5,280 (23.5)	9,600 (42.7)	14,880 (66.2)	21,120 (94.0)	28,800 (128.1)	37,920 (168.7)	48,000 (213.5)	60,960 (271.2)
	Reduction for seismic shear	$\alpha_{V,seis}$	-	0.70							
	Strength reduction factor $\phi$ for tension <sup>3</sup>	$\phi$	-	0.75							
	Strength reduction factor $\phi$ for shear <sup>3</sup>	$\phi$	-	0.65							

For SI: 1 inch = 25.4 mm, 1 lbf = 4.448 N. For pound-inch units: 1 mm = 0.03937 inches, 1 N = 0.2248 lbf

<sup>1</sup>Values provided for common rod material types are based on specified strengths and calculated in accordance with ACI 318-14 Eq. (17.4.1.2) and Eq. (17.5.1.2b); or ACI 318-11 Eq. (D-2) and Eq. (D-29), as applicable. Nuts and washers must be appropriate for the rod.

<sup>2</sup>For use with the load combinations of IBC Section 1605.2, ACI 318-14 5.3 or ACI 318-11 9.2, as applicable, as set forth in ACI 318-14 17.3.3 or ACI 318-11 D.4.3, as applicable. If the load combinations of ACI 318-11 Appendix C are used, the appropriate value of  $\phi$  must be determined in accordance with ACI 318-11 D.4.4. Values correspond to a brittle steel element.

<sup>3</sup>For use with the load combinations of IBC Section 1605.2, ACI 318-14 5.3 or ACI 318-11 9.2, as applicable, as set forth in ACI 318-14 17.3.3 or ACI 318-11 D.4.3, as applicable. If the load combinations of ACI 318-11 Appendix C are used, the appropriate value of  $\phi$  must be determined in accordance with ACI 318-11 D.4.4. Values correspond to a ductile steel element.

喜利得股份有限公司  
送審專用  
FOR REVIEW



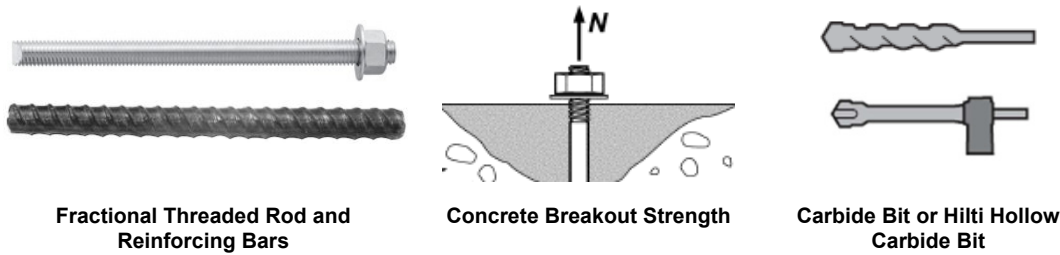

**TABLE 6—CONCRETE BREAKOUT DESIGN INFORMATION FOR FRACTIONAL THREADED ROD AND REINFORCING BARS IN HOLES DRILLED WITH A HAMMER DRILL AND CARBIDE BIT (OR HILTI HOLLOW CARBIDE DRILL BIT)<sup>1</sup>**

DESIGN INFORMATION	Symbol	Units	Nominal rod diameter (in.) / Reinforcing bar size							
			<sup>3</sup> / <sub>8</sub> or #3	<sup>1</sup> / <sub>2</sub> or #4	<sup>5</sup> / <sub>8</sub> or #5	<sup>3</sup> / <sub>4</sub> or #6	<sup>7</sup> / <sub>8</sub> or #7	1 or #8	#9	1 1/4 or #10
Effectiveness factor for cracked concrete	$k_{c,cr}$	in-lb (SI)	17 (7.1)							
Effectiveness factor for uncracked concrete	$k_{c,uncr}$	in-lb (SI)	24 (10)							
Minimum embedment	$h_{ef,min}$	in. (mm)	2 <sup>3</sup> / <sub>8</sub> (60)	2 <sup>3</sup> / <sub>4</sub> (70)	3 <sup>1</sup> / <sub>8</sub> (79)	3 <sup>1</sup> / <sub>2</sub> (89)	3 <sup>1</sup> / <sub>2</sub> (89)	4 (102)	4 <sup>1</sup> / <sub>2</sub> (114)	5 (127)
Maximum embedment	$h_{ef,max}$	in. (mm)	7 <sup>1</sup> / <sub>2</sub> (191)	10 (254)	12 <sup>1</sup> / <sub>2</sub> (318)	15 (381)	17 <sup>1</sup> / <sub>2</sub> (445)	20 (508)	22 <sup>1</sup> / <sub>2</sub> (572)	25 (635)
Minimum anchor spacing <sup>3</sup>	$s_{min}$	in. (mm)	1 <sup>7</sup> / <sub>8</sub> (48)	2 <sup>1</sup> / <sub>2</sub> (64)	3 <sup>1</sup> / <sub>8</sub> (79)	3 <sup>3</sup> / <sub>4</sub> (95)	4 <sup>3</sup> / <sub>8</sub> (111)	5 (127)	5 <sup>5</sup> / <sub>8</sub> (143)	6 <sup>1</sup> / <sub>4</sub> (159)
Minimum edge distance <sup>3</sup>	$c_{min}$	-	5d; or see Section 4.1.9 of this report for design with reduced minimum edge distances							
Minimum concrete thickness	$h_{min}$	in. (mm)	$h_{ef} + 1\frac{1}{4}$ ( $h_{ef} + 30$ )			$h_{ef} + 2d_o^{(4)}$				
Critical edge distance – splitting (for uncracked concrete)	$c_{ac}$	-	See Section 4.1.10 of this report.							
Strength reduction factor for tension, concrete failure modes, Condition B <sup>2</sup>	$\phi$	-	0.65							
Strength reduction factor for shear, concrete failure modes, Condition B <sup>2</sup>	$\phi$	-	0.70							

For **SI**: 1 inch ≡ 25.4 mm, 1 lbf = 4.448 N, 1 psi = 0.006897 MPa.  
 For **pound-inch** units: 1 mm = 0.03937 inches, 1 N = 0.2248 lbf, 1 MPa = 145.0 psi

<sup>1</sup>Additional setting information is described in Figure 9, Manufacturers Printed Installation Instructions (MPII).  
<sup>2</sup>Values provided for post-installed anchors under Condition B without supplementary reinforcement as defined in ACI 318-14 17.3.3 or ACI 318-11 D.4.3, as applicable.  
<sup>3</sup>For installations with 1<sup>3</sup>/<sub>4</sub>-inch edge distance, refer to Section 4.1.9 of this report for spacing and maximum torque requirements.  
<sup>4</sup> $d_o$  = hole diameter.

喜利得股份有限公司  
 送審專用  
 FOR REVIEW

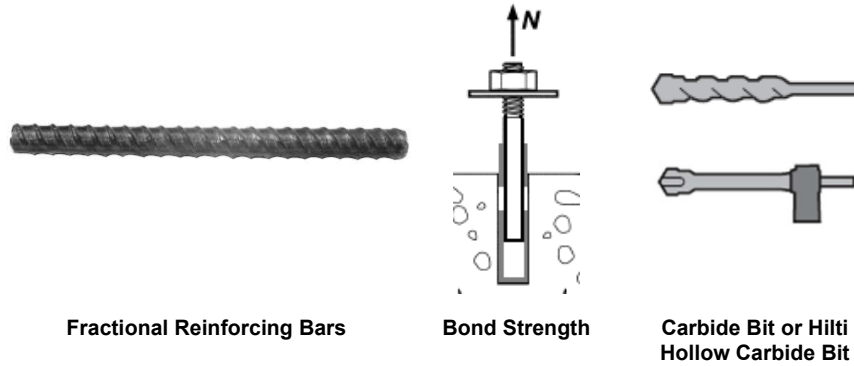

**TABLE 7—BOND STRENGTH DESIGN INFORMATION FOR FRACTIONAL REINFORCING BARS IN HOLES DRILLED WITH A HAMMER DRILL AND CARBIDE BIT (OR HILTI HOLLOW CARBIDE DRILL BIT)<sup>1,2,3,4</sup>**

DESIGN INFORMATION		Symbol	Units	Nominal reinforcing bar size							
				#3	#4	#5	#6	#7	#8	#9	#10
Minimum embedment		$h_{ef,min}$	in. (mm)	2 <sup>3</sup> / <sub>8</sub> (60)	2 <sup>3</sup> / <sub>4</sub> (70)	3 <sup>1</sup> / <sub>8</sub> (79)	3 <sup>1</sup> / <sub>2</sub> (89)	3 <sup>1</sup> / <sub>2</sub> (89)	4 (102)	4 <sup>1</sup> / <sub>2</sub> (114)	5 (127)
Maximum embedment		$h_{ef,max}$	in. (mm)	7 <sup>1</sup> / <sub>2</sub> (191)	10 (254)	12 <sup>1</sup> / <sub>2</sub> (318)	15 (381)	17 <sup>1</sup> / <sub>2</sub> (445)	20 (508)	22 <sup>1</sup> / <sub>2</sub> (572)	25 (635)
Dry concrete	Characteristic bond strength in cracked concrete	$\tau_{k,cr}$	psi (MPa)	476 (3.3)	476 (3.3)	476 (3.3)	476 (3.3)	476 (3.3)	452 (3.1)	428 (3.0)	408 (2.8)
	Characteristic bond strength in uncracked concrete	$\tau_{k,uncr}$	psi (MPa)	1,272 (8.8)	1,256 (8.7)	1,204 (8.3)	1,164 (8.0)	1,124 (7.8)	1,092 (7.5)	1,068 (7.4)	1,048 (7.2)
	Anchor category	-	-	2							
	Strength reduction factor	$\phi_s$	-	0.55							
Water saturated concrete, water-filled hole and underwater application	Characteristic bond strength in cracked concrete	$\tau_{k,cr}$	psi (MPa)	424 (2.9)	420 (2.9)	420 (2.9)	405 (2.8)	386 (2.7)	356 (2.5)	330 (2.3)	300 (2.1)
	Characteristic bond strength in uncracked concrete	$\tau_{k,uncr}$	psi (MPa)	1,133 (7.8)	1,106 (7.6)	1,061 (7.3)	994 (6.9)	915 (6.3)	919 (6.3)	821 (5.7)	776 (5.4)
	Anchor category	-	-	3							
	Strength reduction factor	$\phi_{ws}$ $\phi_{wf}$ $\phi_{uw}$	-	0.45							

For **SI**: 1 inch = 25.4 mm, 1 lbf = 4.448 N, 1 psi = 0.006897 MPa.  
 For **pound-inch** units: 1 mm = 0.03937 inches, 1 N = 0.2248 lbf, 1 MPa = 145.0 psi

<sup>1</sup>Bond strength values correspond to concrete compressive strength  $f_c = 2,500$  psi (17.2 MPa). For concrete compressive strength,  $f_c$ , between 2,500 psi (17.2 MPa) and 8,000 psi (55.2 MPa), the tabulated characteristic bond strength may be increased by a factor of  $(f_c / 2,500)^{0.1}$  [For SI:  $(f_c / 17.2)^{0.1}$ ]. See Section 4.1.4 of this report for bond strength determination.

<sup>2</sup>Bond strength values are for sustained loads including dead and live loads. For load combinations consisting of short-term loads only such as wind and seismic, bond strengths may be increased 40 percent.

<sup>3</sup>Values are for the following temperature range: maximum short term temperature = 130°F (55°C), maximum long term temperature = 110°F (43°C). Short term elevated concrete temperatures are those that occur over brief intervals, e.g., as a result of diurnal cycling. Long term concrete temperatures are roughly constant over significant periods of time.

<sup>4</sup>For structures assigned to Seismic Design Categories C, D, E or F, bond strength values must be multiplied by  $\alpha_{N,seis} = 0.90$ .

喜利得股份有限公司

送審專用

FOR REVIEW

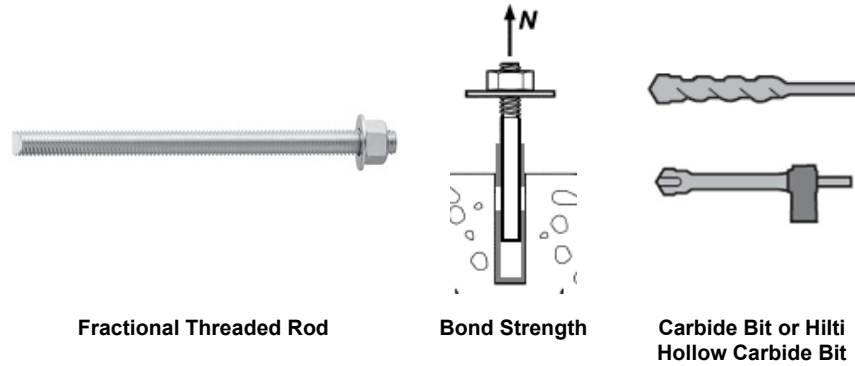

TABLE 8—BOND STRENGTH DESIGN INFORMATION FOR FRACTIONAL THREADED ROD IN HOLES DRILLED WITH A HAMMER DRILL AND CARBIDE BIT (OR HILTI HOLLOW CARBIDE DRILL BIT)<sup>1,2,3,4</sup>

DESIGN INFORMATION		Symbol	Units	Nominal rod diameter (in.)						
				3/8	1/2	5/8	3/4	7/8	1	1 1/4
Minimum embedment		$h_{ef,min}$	in. (mm)	2 3/8 (60)	2 3/4 (70)	3 1/8 (79)	3 1/2 (89)	3 1/2 (89)	4 (102)	5 (127)
Maximum embedment		$h_{ef,max}$	in. (mm)	7 1/2 (191)	10 (254)	12 1/2 (318)	15 (381)	17 1/2 (445)	20 (508)	25 (635)
Dry concrete	Characteristic bond strength in cracked concrete	$\tau_{k,cr}$	psi (MPa)	662 (4.6)	592 (4.1)	592 (4.1)	560 (3.9)	516 (3.6)	480 (3.3)	408 (2.8)
	Characteristic bond strength in uncracked concrete	$\tau_{k,uncr}$	psi (MPa)	1,272 (8.8)	1,256 (8.7)	1,204 (8.3)	1,164 (8.0)	1,124 (7.8)	1,092 (7.5)	1,048 (7.2)
	Anchor category	-	-	2						
	Strength reduction factor	$\phi_d$	-	0.55						
Water saturated concrete, water-filled hole and underwater application	Characteristic bond strength in cracked concrete	$\tau_{k,cr}$	psi (MPa)	548 (3.8)	521 (3.6)	521 (3.6)	476 (3.3)	416 (2.9)	375 (2.6)	300 (2.1)
	Characteristic bond strength in uncracked concrete	$\tau_{k,uncr}$	psi (MPa)	1,133 (7.8)	1,106 (7.6)	1,061 (7.3)	994 (6.9)	915 (6.3)	859 (5.9)	776 (5.4)
	Anchor category	-	-	3						
	Strength reduction factor	$\phi_{ws}$ $\phi_{wt}$ $\phi_{uw}$	-	0.45						

For SI: 1 inch = 25.4 mm, 1 lbf = 4.448 N, 1 psi = 0.006897 MPa.

For pound-inch units: 1 mm = 0.03937 inches, 1 N = 0.2248 lbf, 1 MPa = 145.0 psi

<sup>1</sup>Bond strength values correspond to concrete compressive strength  $f'_c = 2,500$  psi (17.2 MPa). For concrete compressive strength,  $f'_c$ , between 2,500 psi (17.2 MPa) and 8,000 psi (55.2 MPa), the tabulated characteristic bond strength may be increased by a factor of  $(f'_c / 2,500)^{0.1}$  [For SI:  $(f'_c / 17.2)^{0.1}$ ]. See Section 4.1.4 of this report for bond strength determination.

<sup>2</sup>Bond strength values are for sustained loads including dead and live loads. For load combinations consisting of short-term loads only such as wind and seismic, bond strengths may be increased 40 percent.

<sup>3</sup>Values are for the following temperature range: maximum short term temperature = 130°F (55°C), maximum long term temperature = 110°F (43°C). Short-term elevated concrete temperatures are those that occur over brief intervals, e.g., as a result of diurnal cycling. Long-term concrete temperatures are roughly constant over significant periods of time.

<sup>4</sup>For structures assigned to Seismic Design Categories C, D, E or F, bond strength values must be multiplied by  $\alpha_{N,seis} = 0.90$ .

喜利得股份有限公司  
送審專用  
FOR REVIEW



TABLE 9—STEEL DESIGN INFORMATION FOR METRIC THREADED ROD AND EU METRIC REINFORCING BARS

DESIGN INFORMATION		Symbol	Units	Nominal rod diameter (mm) <sup>1</sup>								
				8	10	12	16	20	24	27	30	
Rod outside diameter		<i>d</i>	mm (in.)	8 (0.31)	10 (0.39)	12 (0.47)	16 (0.63)	20 (0.79)	24 (0.94)	27 (1.06)	30 (1.18)	
Rod effective cross-sectional area		<i>A<sub>se</sub></i>	mm <sup>2</sup> (in. <sup>2</sup> )	36.6 (0.057)	58.0 (0.090)	84.3 (0.131)	157 (0.243)	245 (0.380)	353 (0.547)	459 (0.711)	561 (0.870)	
ISO 898-1 Class 5.8	Nominal strength as governed by steel strength	<i>N<sub>sa</sub></i>	kN (lb)	18.5 (4,114)	29.0 (6,519)	42.0 (9,476)	78.5 (17,647)	122.5 (27,539)	176.5 (39,679)	229.5 (51,594)	280.5 (63,059)	
		<i>V<sub>sa</sub></i>	kN (lb)	11.0 (2,480)	14.5 (3,260)	25.5 (5,685)	47.0 (10,588)	73.5 (16,523)	106.0 (23,807)	137.5 (30,956)	168.5 (37,835)	
	Reduction for seismic shear	<i>α<sub>V,seis</sub></i>	-	0.70								
	Strength reduction factor for tension <sup>2</sup>	<i>φ</i>	-	0.65								
	Strength reduction factor for shear <sup>2</sup>	<i>φ</i>	-	0.60								
ISO 898-1 Class 8.8	Nominal strength as governed by steel strength	<i>N<sub>sa</sub></i>	kN (lb)	29.5 (6,582)	46.5 (10,431)	67.5 (15,161)	125.5 (28,236)	196.0 (44,063)	282.5 (63,486)	367.0 (82,550)	449.0 (100,894)	
		<i>V<sub>sa</sub></i>	kN (lb)	17.6 (3,949)	23.0 (5,216)	40.5 (9,097)	75.5 (16,942)	117.5 (26,438)	169.5 (38,092)	220.5 (49,530)	269.5 (60,537)	
	Reduction for seismic shear	<i>α<sub>V,seis</sub></i>	-	0.70								
	Strength reduction factor for tension <sup>2</sup>	<i>φ</i>	-	0.65								
	Strength reduction factor for shear <sup>2</sup>	<i>φ</i>	-	0.60								
ISO 3506-1 Class A4 Stainless <sup>3</sup>	Nominal strength as governed by steel strength	<i>N<sub>sa</sub></i>	kN (lb)	25.6 (5,760)	40.6 (9,127)	59.0 (13,266)	109.9 (24,706)	171.5 (38,555)	247.1 (55,550)	229.5 (51,594)	280.5 (63,059)	
		<i>V<sub>sa</sub></i>	kN (lb)	15.4 (3,456)	20.3 (4,564)	35.4 (7,960)	65.9 (14,824)	102.9 (23,133)	148.3 (33,330)	137.7 (30,956)	168.3 (37,835)	
	Reduction for seismic shear	<i>α<sub>V,seis</sub></i>	-	0.70								
	Strength reduction factor for tension <sup>2</sup>	<i>φ</i>	-	0.65								
	Strength reduction factor for shear <sup>2</sup>	<i>φ</i>	-	0.60								
DESIGN INFORMATION		Symbol	Units	Reinforcing bar size								
				8	10	12	14	16	20	25	28	32
Nominal bar diameter		<i>d</i>	mm (in.)	8.0 (0.315)	10.0 (0.394)	12.0 (0.472)	14.0 (0.551)	16.0 (0.630)	20.0 (0.787)	25.0 (0.984)	28.0 (1.102)	32.0 (1.260)
Bar effective cross-sectional area		<i>A<sub>se</sub></i>	mm <sup>2</sup> (in. <sup>2</sup> )	50.3 (0.078)	78.5 (0.122)	113.1 (0.175)	153.9 (0.239)	201.1 (0.312)	314.2 (0.487)	490.9 (0.761)	615.8 (0.954)	804.2 (1.247)
DIN 488 BSt 550/500	Nominal strength as governed by steel strength	<i>N<sub>sa</sub></i>	kN (lb)	27.5 (6,215)	43.0 (9,711)	62.0 (13,984)	84.5 (19,034)	110.5 (24,860)	173.0 (38,844)	270.0 (60,694)	338.5 (76,135)	442.5 (99,441)
		<i>V<sub>sa</sub></i>	kN (lb)	16.5 (3,729)	26.0 (5,827)	37.5 (8,390)	51.0 (11,420)	66.5 (14,916)	103.0 (23,307)	162.0 (36,416)	203.0 (45,681)	265.5 (59,665)
	Reduction for seismic shear	<i>α<sub>V,seis</sub></i>	-	0.70								
	Strength reduction factor for tension <sup>2</sup>	<i>φ</i>	-	0.65								
	Strength reduction factor for shear <sup>2</sup>	<i>φ</i>	-	0.60								

For SI: 1 inch ≅ 25.4 mm, 1 lbf = 4.448 N, 1 psi = 0.006897 MPa.  
 For pound-inch units: 1 mm = 0.03937 inches, 1 N = 0.2248 lbf, 1 MPa = 145.0 psi

<sup>1</sup>Values provided for common rod material types are based on specified strengths and calculated in accordance with ACI 318-14 Eq. (17.4.1.2) and Eq. (17.5.1.2b); or ACI 318-11 Eq. (D-2) and Eq. (D-29), as applicable. Nuts and washers must be appropriate for the rod.

<sup>2</sup>For use with the load combinations of IBC Section 1605.2, ACI 318-14 5.3, or ACI 318-11 9.2, as applicable, as set forth in ACI 318-14 17.3.3 or ACI 318-11 D.4.3, as applicable. If the load combinations of ACI 318-11 Appendix C are used, the appropriate value of *φ* must be determined in accordance with ACI 318-11 D.4.4. Values correspond to a brittle steel element.

<sup>3</sup>A4-70 Stainless (M8- M24); A4-502 Stainless (M27- M30).

喜利得股份有限公司  
 送審專用  
 FOR REVIEW

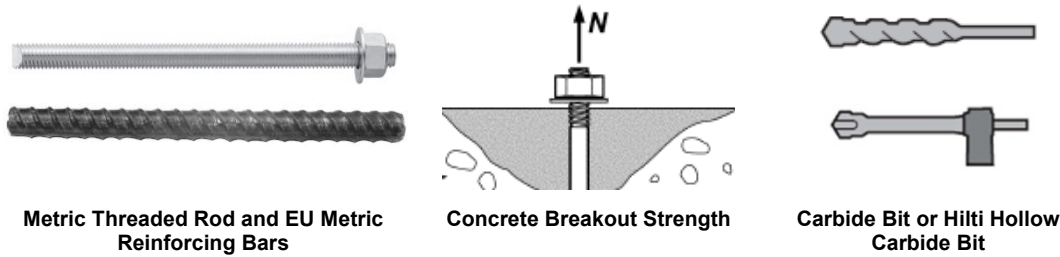

**TABLE 10—CONCRETE BREAKOUT DESIGN INFORMATION FOR METRIC THREADED ROD AND EU METRIC REINFORCING BARS IN HOLES DRILLED WITH A HAMMER DRILL AND CARBIDE BIT (OR HILTI HOLLOW CARBIDE DRILL BIT)<sup>1</sup>**

DESIGN INFORMATION	Symbol	Units	Nominal rod diameter (mm)								
			8	10	12	16	20	24	27	30	
Effectiveness factor for cracked concrete	$k_{c,cr}$	SI (in-lb)	7.1 (17)								
Effectiveness factor for uncracked concrete	$k_{c,un-cr}$	SI (in-lb)	10 (24)								
Minimum anchor spacing <sup>3</sup>	$s_{min}$	mm (in.)	40 (1.6)	50 (2.0)	60 (2.4)	80 (3.2)	100 (3.9)	120 (4.7)	135 (5.3)	150 (5.9)	
Minimum edge distance <sup>3</sup>	$c_{min}$	mm (in.)	40 (1.6)	50 (2.0)	60 (2.4)	80 (3.2)	100 (3.9)	120 (4.7)	135 (5.3)	150 (5.9)	
Minimum concrete thickness	$h_{min}$	mm (in.)	$h_{ef} + 30$ ( $h_{ef} + 1\frac{1}{4}$ )			$h_{ef} + 2d_o^{(4)}$					
Critical edge distance – splitting (for uncracked concrete)	$c_{ac}$	-	See Section 4.1.10 of this report.								
Strength reduction factor for tension, concrete failure modes, Condition B <sup>2</sup>	$\phi$	-	0.65								
Strength reduction factor for shear, concrete failure modes, Condition B <sup>2</sup>	$\phi$	-	0.70								
DESIGN INFORMATION	Symbol	Units	Reinforcing bar size								
			8	10	12	14	16	20	25	28	32
Effectiveness factor for cracked concrete	$k_{c,cr}$	SI (in-lb)	7.1 (17)								
Effectiveness factor for uncracked concrete	$k_{c,un-cr}$	SI (in-lb)	10 (24)								
Minimum bar spacing <sup>3</sup>	$s_{min}$	mm (in.)	40 (1.6)	50 (2.0)	60 (2.4)	70 (2.8)	80 (3.1)	100 (3.9)	125 (4.9)	140 (5.5)	160 (6.3)
Minimum edge distance <sup>3</sup>	$c_{min}$	-	40 (1.6)	50 (2.0)	60 (2.4)	70 (2.8)	80 (3.1)	100 (3.9)	125 (4.9)	140 (5.5)	160 (6.3)
Minimum concrete thickness	$h_{min}$	mm (in.)	$h_{ef} + 30$ ( $h_{ef} + 1\frac{1}{4}$ )			$h_{ef} + 2d_o^{(4)}$					
Critical edge distance – splitting (for uncracked concrete)	$c_{ac}$	-	See Section 4.1.10 of this report.								
Strength reduction factor for tension, concrete failure modes, Condition B <sup>2</sup>	$\phi$	-	0.65								
Strength reduction factor for shear, concrete failure modes, Condition B <sup>2</sup>	$\phi$	-	0.70								

For SI: 1 inch = 25.4 mm, 1 lbf = 4.448 N, 1 psi = 0.006897 MPa.

For pound-inch units: 1 mm = 0.03937 inches, 1 N = 0.2248 lbf, 1 MPa = 145.0 psi

<sup>1</sup>Additional setting information is described in Figure 9, Manufacturers Printed Installation Instructions (MPII).

<sup>2</sup>Values provided for post-installed anchors installed under Condition B without supplementary reinforcement as defined in ACI 318-14 17.3.3 or ACI 318-11 D.4.3, as applicable.

<sup>3</sup>For installations with 1<sup>3</sup>/<sub>4</sub>-inch edge distance, refer to Section 4.1.9 for spacing and maximum torque requirements.

<sup>4</sup>  $d_o$  = hole diameter.

喜利得股份有限公司

送審專用

FOR REVIEW

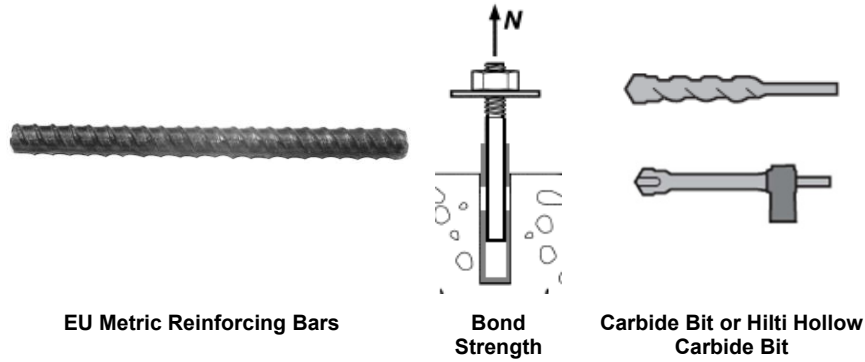

**TABLE 11—BOND STRENGTH DESIGN INFORMATION FOR EU METRIC REINFORCING BARS IN HOLES DRILLED WITH A HAMMER DRILL AND CARBIDE BIT (OR HILTI HOLLOW CARBIDE DRILL BIT)<sup>1,2,3,4</sup>**

DESIGN INFORMATION		Symbol	Units	Reinforcing bar size								
				8	10	12	14	16	20	25	28	32
Minimum embedment		$h_{ef,min}$	mm (in.)	60 (2.4)	60 (2.4)	70 (2.8)	75 (3.0)	80 (3.1)	90 (3.5)	100 (3.9)	112 (4.4)	128 (5.0)
Maximum embedment		$h_{ef,max}$	mm (in.)	160 (6.3)	200 (7.9)	240 (9.4)	280 (11.0)	320 (12.6)	400 (15.7)	500 (19.7)	560 (22.0)	640 (25.2)
Dry concrete	Characteristic bond strength in cracked concrete	$\tau_{k,cr}$	MPa (psi)	-	3.3 (472)	3.3 (472)	3.3 (472)	3.3 (472)	3.3 (472)	3.2 (464)	3.0 (428)	2.8 (408)
	Characteristic bond strength in uncracked concrete	$\tau_{k,uncr}$	MPa (psi)	8.8 (1,272)	8.8 (1,272)	8.8 (1,272)	8.5 (1,236)	8.3 (1,204)	7.9 (1,148)	7.6 (1,100)	7.4 (1,072)	7.2 (1,048)
	Anchor category	-	-	2								
	Strength reduction factor	$\phi_{cl}$	-	0.55								
Water saturated concrete, water-filled hole and underwater application	Characteristic bond strength in cracked concrete	$\tau_{k,cr}$	MPa (psi)	-	2.9 (424)	2.9 (420)	2.9 (420)	2.8 (413)	2.8 (401)	2.6 (371)	2.3 (330)	2.1 (300)
	Characteristic bond strength in uncracked concrete	$\tau_{k,uncr}$	MPa (psi)	7.8 (1,133)	7.8 (1,133)	7.7 (1,121)	7.6 (1,095)	7.2 (1,050)	6.7 (968)	6.1 (878)	5.7 (825)	5.4 (776)
	Anchor category	-	-	3								
	Strength reduction factor	$\phi_{ws}$ $\phi_{wf}$ $\phi_{uw}$	-	0.45								

For **SI**: 1 inch  $\equiv$  25.4 mm, 1 lbf = 4.448 N, 1 psi = 0.006897 MPa.  
 For **pound-inch** units: 1 mm = 0.03937 inches, 1 N = 0.2248 lbf, 1 MPa = 145.0 psi

<sup>1</sup>Bond strength values correspond to concrete compressive strength  $f_c = 2,500$  psi (17.2 MPa). For concrete compressive strength,  $f_c$ , between 2,500 psi (17.2 MPa) and 8,000 psi (55.2 MPa), the tabulated characteristic bond strength may be increased by a factor of  $(f_c / 2,500)^{0.1}$  [For SI:  $(f_c / 17.2)^{0.1}$ ]. See Section 4.1.4 of this report for bond strength determination.

<sup>2</sup>Bond strength values are for sustained loads including dead and live loads. For load combinations consisting of short-term loads only such as wind and seismic, bond strengths may be increased 40 percent.

<sup>3</sup>Values are for the following temperature range: maximum short term temperature = 130°F (55°C), maximum long term temperature = 110°F (43°C). Short term elevated concrete temperatures are those that occur over brief intervals, e.g., as a result of diurnal cycling. Long term concrete temperatures are roughly constant over significant periods of time.

<sup>4</sup>For structures assigned to Seismic Design Categories C, D, E or F, bond strength values must be multiplied by  $\alpha_{N,seis} = 0.90$ .

喜利得股份有限公司  
 送審專用  
 FOR REVIEW

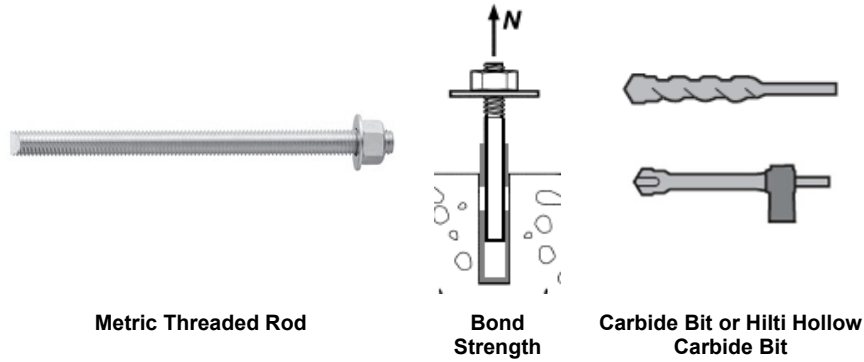

**TABLE 12—BOND STRENGTH DESIGN INFORMATION FOR METRIC THREADED ROD IN HOLES DRILLED WITH A HAMMER DRILL AND CARBIDE BIT (OR HILTI HOLLOW CARBIDE DRILL BIT)<sup>1,2,3,4</sup>**

DESIGN INFORMATION		Symbol	Units	Nominal rod diameter (mm)							
				8	10	12	16	20	24	27	30
Minimum embedment		$h_{ef,min}$	mm (in.)	60 (2.4)	60 (2.4)	70 (2.8)	80 (3.1)	90 (3.5)	96 (3.8)	108 (4.3)	120 (4.7)
Maximum embedment		$h_{ef,max}$	mm (in.)	160 (6.3)	200 (7.9)	240 (9.4)	320 (12.6)	400 (15.7)	480 (18.9)	540 (21.3)	600 (23.6)
Dry concrete	Characteristic bond strength in cracked concrete	$\tau_{k,cr}$	MPa (psi)	-	4.6 (662)	4.1 (592)	4.1 (592)	3.9 (560)	3.6 (516)	3.3 (480)	2.8 (408)
	Characteristic bond strength in uncracked concrete	$\tau_{k,uncr}$	MPa (psi)	8.8 (1,272)	8.8 (1,272)	8.7 (1,256)	8.3 (1,204)	8.0 (1,164)	7.8 (1,124)	7.5 (1,092)	7.2 (1,048)
	Anchor category	-	-	2							
	Strength reduction factor	$\phi_{cl}$	-	0.55							
Water saturated concrete, water-filled hole and underwater application	Characteristic bond strength in cracked concrete	$\tau_{k,cr}$	MPa (psi)	-	3.8 (548)	3.6 (521)	3.6 (521)	3.3 (476)	2.9 (416)	2.6 (375)	2.1 (300)
	Characteristic bond strength in uncracked concrete	$\tau_{k,uncr}$	MPa (psi)	7.8 (1,133)	7.8 (1,133)	7.6 (1,106)	7.3 (1,061)	6.9 (994)	6.3 (915)	5.9 (859)	5.4 (776)
	Anchor category	-	-	3							
	Strength reduction factor	$\phi_{ws}$ $\phi_{wf}$ $\phi_{uw}$	-	0.45							

For **SI**: 1 inch  $\equiv$  25.4 mm, 1 lbf = 4.448 N, 1 psi = 0.006897 MPa.

For **pound-inch** units: 1 mm = 0.03937 inches, 1 N = 0.2248 lbf, 1 MPa = 145.0 psi

<sup>1</sup>Bond strength values correspond to concrete compressive strength  $f'_c = 2,500$  psi (17.2 MPa). For concrete compressive strength,  $f'_c$ , between 2,500 psi (17.2 MPa) and 8,000 psi (55.2 MPa), the tabulated characteristic bond strength may be increased by a factor of  $(f'_c / 2,500)^{0.1}$  [For SI:  $(f'_c / 17.2)^{0.1}$ ]. See Section 4.1.4 of this report for bond strength determination.

<sup>2</sup>Bond strength values are for sustained loads including dead and live loads. For load combinations consisting of short-term loads only such as wind and seismic, bond strengths may be increased 40 percent.

<sup>3</sup>Values are for the following temperature range: maximum short term temperature = 130°F (55°C), maximum long term temperature = 110°F (43°C). Short term elevated concrete temperatures are those that occur over brief intervals, e.g., as a result of diurnal cycling. Long term concrete temperatures are roughly constant over significant periods of time.

<sup>4</sup>For structures assigned to Seismic Design Categories C, D, E or F, bond strength values must be multiplied by  $\alpha_{N,seis} = 0.90$ .

喜利得股份有限公司  
送審專用  
FOR REVIEW



TABLE 13—STEEL DESIGN INFORMATION FOR CANADIAN METRIC REINFORCING BARS<sup>1</sup>

DESIGN INFORMATION		Symbol	Units	Bar size				
				10 M	15 M	20 M	25 M	30 M
Nominal bar diameter		$d$	mm (in.)	11.3 (0.445)	16.0 (0.630)	19.5 (0.768)	25.2 (0.992)	29.9 (1.177)
Bar effective cross-sectional area		$A_{se}$	mm <sup>2</sup> (in. <sup>2</sup> )	100.3 (0.155)	201.1 (0.312)	298.6 (0.463)	498.8 (0.773)	702.2 (1.088)
CSA G30	Nominal strength as governed by steel strength	$N_{sa}$	kN (lb)	54.0 (12,175)	108.5 (24,408)	161.5 (36,255)	270.0 (60,548)	380.0 (85,239)
		$V_{sa}$	kN (lb)	32.5 (7,305)	65.0 (14,645)	97.0 (21,753)	161.5 (36,329)	227.5 (51,144)
	Reduction for seismic shear	$\alpha_{V,seis}$	-	0.70				
	Strength reduction factor for tension <sup>2</sup>	$\phi$	-	0.65				
	Strength reduction factor for shear <sup>2</sup>	$\phi$	-	0.60				

For SI: 1 inch ≅ 25.4 mm, 1 lbf = 4.448 N, 1 psi = 0.006897 MPa.

For pound-inch units: 1 mm = 0.03937 inches, 1 N = 0.2248 lbf, 1 MPa = 145.0 psi

<sup>1</sup>Values provided for common rod material types based on specified strengths and calculated in accordance with ACI 318-14 Eq.(17.4.1.2) and Eq. (17.5.1.2b); or ACI 318-11 Eq. (D-2) and Eq. (D-29), as applicable. Other material specifications are admissible.

<sup>2</sup>For use with the load combinations of ACI 318-14 5.3 or ACI 318-11 9.2, as set forth in ACI 318-14 17.3.3 or ACI 318-11 D.4.3, as applicable.

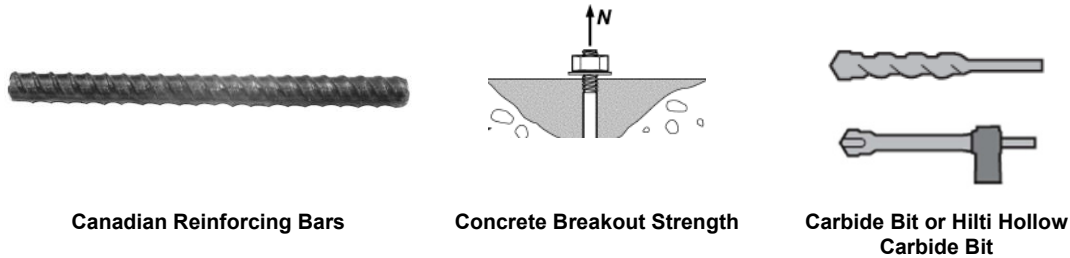

TABLE 14—CONCRETE BREAKOUT DESIGN INFORMATION FOR CANADIAN METRIC REINFORCING BARS IN HOLES DRILLED WITH A HAMMER DRILL AND CARBIDE BIT (OR HILTI HOLLOW CARBIDE DRILL BIT)<sup>1</sup>

DESIGN INFORMATION	Symbol	Units	Bar size				
			10 M	15 M	20 M	25 M	30 M
Effectiveness factor for cracked concrete	$k_{c,cr}$	SI (in-lb)	7.1 (17)				
Effectiveness factor for uncracked concrete	$k_{c,uncr}$	SI (in-lb)	10 (24)				
Minimum embedment	$h_{ef,min}$	mm (in.)	60 (2.4)	80 (3.1)	90 (3.5)	101 (4.0)	120 (4.7)
Maximum embedment	$h_{ef,max}$	mm (in.)	226 (8.9)	320 (12.6)	390 (15.4)	504 (19.8)	598 (23.5)
Minimum bar spacing <sup>3</sup>	$s_{min}$	mm (in.)	57 (2.2)	80 (3.1)	98 (3.8)	126 (5.0)	150 (5.9)
Minimum edge distance <sup>3</sup>	$c_{min}$	mm (in.)	5d; or see Section 4.1.9 of this report for design with reduced minimum edge distances				
Minimum concrete thickness	$h_{min}$	mm (in.)	$h_{ef} + 30$ ( $h_{ef} + 1\frac{1}{4}$ )	$h_{ef} + 2d_o^{(4)}$			
Critical edge distance – splitting (for uncracked concrete)	$c_{ac}$	-	See Section 4.1.10 of this report.				
Strength reduction factor for tension, concrete failure modes, Condition B <sup>2</sup>	$\phi$	-	0.65				
Strength reduction factor for shear, concrete failure modes, Condition B <sup>2</sup>	$\phi$	-	0.70				

For SI: 1 inch ≅ 25.4 mm, 1 lbf = 4.448 N, 1 psi = 0.006897 MPa.

For pound-inch units: 1 mm = 0.03937 inches, 1 N = 0.2248 lbf, 1 MPa = 145.0 psi

<sup>1</sup>Additional setting information is described in Figure 9, Manufacturers Printed Installation Instructions (MPII).

<sup>2</sup>Values provided for post-installed anchors installed under Condition B without supplementary reinforcement.

<sup>3</sup>For installations with 1<sup>3</sup>/<sub>4</sub>-inch edge distance, refer to Section 4.1.9 of this report for spacing and maximum torque requirements.

<sup>4</sup>  $d_o$  = hole diameter.

喜利得股份有限公司

送審專用

FOR REVIEW



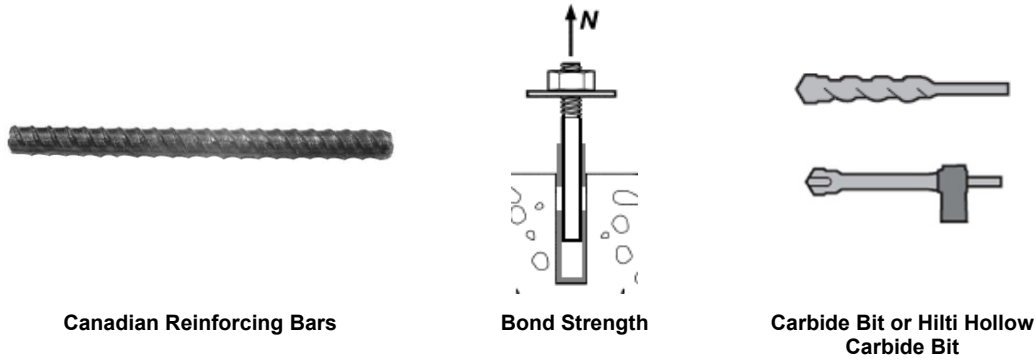

**TABLE 15—BOND STRENGTH DESIGN INFORMATION FOR CANADIAN METRIC REINFORCING BARS IN HOLES DRILLED WITH A HAMMER DRILL AND CARBIDE BIT (OR HILTI HOLLOW CARBIDE DRILL BIT)<sup>1,2,3,4</sup>**

DESIGN INFORMATION		Symbol	Units	Bar size				
				10 M	15 M	20 M	25 M	30 M
Minimum embedment		$h_{ef,min}$	mm (in.)	60 (2.8)	80 (3.1)	90 (3.5)	101 (4.0)	120 (4.7)
Maximum embedment		$h_{ef,max}$	mm (in.)	226 (8.9)	320 (12.6)	390 (15.4)	504 (19.8)	598 (23.5)
Dry concrete	Characteristic bond strength in cracked concrete	$\tau_{k,cr}$	MPa (psi)	3.3 (476)	3.3 (476)	3.3 (476)	3.3 (476)	2.9 (416)
	Characteristic bond strength in uncracked concrete	$\tau_{k,uncr}$	MPa (psi)	8.8 (1,272)	8.3 (1,204)	8.0 (1,156)	7.6 (1,100)	7.3 (1,056)
	Anchor category	-	-	2				
	Strength reduction factor	$\phi_d$	-	0.55				
Water saturated concrete, water-filled hole and underwater application	Characteristic bond strength in cracked concrete	$\tau_{k,cr}$	MPa (psi)	2.9 (424)	2.9 (420)	2.8 (405)	2.5 (360)	2.2 (319)
	Characteristic bond strength in uncracked concrete	$\tau_{k,uncr}$	MPa (psi)	7.8 (1,133)	7.3 (1,061)	6.8 (986)	6.1 (878)	5.5 (803)
	Anchor category	-	-	3				
	Strength reduction factor	$\phi_{ws}$ $\phi_{wf}$ $\phi_{uw}$	-	0.45				

For SI: 1 inch  $\equiv$  25.4 mm, 1 lbf = 4.448 N, 1 psi = 0.006897 MPa.

For pound-inch units: 1 mm = 0.03937 inches, 1 N = 0.2248 lbf, 1 MPa = 145.0 psi

<sup>1</sup>Bond strength values correspond to concrete compressive strength  $f'_c = 2,500$  psi (17.2 MPa). For concrete compressive strength,  $f'_c$ , between 2,500 psi (17.2 MPa) and 8,000 psi (55.2 MPa), the tabulated characteristic bond strength may be increased by a factor of  $(f'_c / 2,500)^{0.1}$  [For SI:  $(f'_c / 17.2)^{0.1}$ ]. See Section 4.1.4 of this report for bond strength determination.

<sup>2</sup>Bond strength values are for sustained loads including dead and live loads. For load combinations consisting of short-term loads only such as wind and seismic, bond strengths may be increased 40 percent.

<sup>3</sup>Values are for the following temperature range: maximum short term temperature = 130°F (55°C), maximum long term temperature = 110°F (43°C). Short term elevated concrete temperatures are those that occur over brief intervals, e.g., as a result of diurnal cycling. Long term concrete temperatures are roughly constant over significant periods of time.

<sup>4</sup>For structures assigned to Seismic Design Categories C, D, E or F, bond strength values must be multiplied by  $\alpha_{N,seis} = 0.90$ .

喜利得股份有限公司

送審專用

FOR REVIEW

**TABLE 16—DEVELOPMENT LENGTH FOR U.S. CUSTOMARY UNIT REINFORCING BARS IN HOLES DRILLED WITH A HAMMER DRILL AND CARBIDE BIT (OR HILTI HOLLOW CARBIDE BIT)** <sup>1,2,3,5,6</sup>

DESIGN INFORMATION	Symbol	Criteria Section of Reference Standard	Units	Bar Size							
				#3	#4	#5	#6	#7	#8	#9	#10
Nominal reinforcing bar diameter	$d_b$	ASTM A615/A706	in. (mm)	0.375 (9.5)	0.500 (12.7)	0.625 (15.9)	0.750 (19.1)	0.875 (22.2)	1.000 (25.4)	1.125 (28.6)	1.250 (31.8)
Nominal bar area	$A_b$	ASTM A615/A706	in <sup>2</sup> (mm <sup>2</sup> )	0.11 (71.3)	0.20 (126.7)	0.31 (197.9)	0.44 (285.0)	0.60 (387.9)	0.79 (506.7)	1.00 (644.7)	1.27 (817.3)
Development length for $f_y = 60$ ksi and $f_c = 2,500$ psi (normal weight concrete) <sup>4</sup>	$l_d$	ACI 318-14 25.4.2.3	in. (mm)	12.0 (305)	14.4 (366)	18.0 (457)	21.6 (549)	31.5 (800)	36.0 (914)	40.5 (1029)	45.0 (1143)
Development length for $f_y = 60$ ksi and $f_c = 4,000$ psi (normal weight concrete) <sup>4</sup>	$l_d$	ACI 318-14 25.4.2.3 12.2.3	in. (mm)	12.0 (305)	12.0 (305)	14.2 (361)	17.1 (434)	24.9 (633)	28.5 (723)	32.0 (813)	35.6 (904)

For **SI**: 1 inch = 25.4 mm, 1 lbf = 4.448 N, 1 psi = 0.006897 Mpa  
 For **pound-inch** units: 1 mm = 0.03937 inches, 1 N = 0.2248 lbf, 1 Mpa = 145.0 psi

<sup>1</sup>Development lengths valid for static, wind, and earthquake loads (SDC A and B).  
<sup>2</sup>Development lengths in SDC C through F must comply with ACI 318-14 Chapter 18 or ACI 318-11 Chapter 21, as applicable, and section 4.2.4 of this report. The value of  $f_c$  used to calculate development lengths shall not exceed 2,500 psi for post-installed reinforcing bar applications in SDCs C, D, E, and F.  
<sup>3</sup>For all-lightweight concrete, increase development length by 33%, unless the provisions of ACI 318-14 25.4.2.4 or ACI 318-11 12.2.4 (d), as applicable, are met to permit  $\lambda > 0.75$ . For sand-lightweight concrete, increase development length by 18%, unless the provisions of ACI 318-14 25.4.2.4 or ACI 318-11 12.2.4 (d), as applicable, are met to permit  $\lambda > 0.85$ .  
<sup>4</sup> $\left(\frac{c_b + K_{tr}}{d_b}\right) = 2.5$ ,  $\psi_t = 1.0$ ,  $\psi_e = 1.0$ ,  $\psi_s = 0.8$  for  $d_b \leq \#6$ , 1.0 for  $d_b > \#6$   
<sup>5</sup>Calculations may be performed for other steel grades per ACI 318-11 Chapter 12 or ACI 318-14 Chapter 25.  
<sup>6</sup>Minimum development length shall not be less than 12 in (305 mm) per ACI 318-14 Section 25.4.2.1

**TABLE 17—DEVELOPMENT LENGTH FOR EU METRIC REINFORCING BARS IN HOLES DRILLED WITH A HAMMER DRILL AND CARBIDE BIT (OR HILTI HOLLOW CARBIDE BIT)** <sup>1,2,3,5,6</sup>

DESIGN INFORMATION	Symbol	Criteria Section of Reference Standard	Units	Bar Size						
				8	10	12	16	20	25	32
Nominal reinforcing bar diameter	$d_b$	BS4449: 2005	mm (in.)	8 (0.315)	10 (0.394)	12 (0.472)	16 (0.630)	20 (0.787)	25 (0.984)	32 (1.260)
Nominal bar area	$A_b$	BS 4449: 2005	mm <sup>2</sup> (in <sup>2</sup> )	50.3 (0.08)	78.5 (0.12)	113.1 (0.18)	201.1 (0.31)	314.2 (0.49)	490.9 (0.76)	804.2 (1.25)
Development length for $f_y = 72.5$ ksi and $f_c = 2,500$ psi (normal weight concrete) <sup>4</sup>	$l_d$	ACI 318 12.2.3	mm (in.)	305 (12.0)	348 (13.7)	417 (16.4)	556 (21.9)	871 (34.3)	1087 (42.8)	1392 (54.8)
Development length for $f_y = 72.5$ ksi and $f_c = 4,000$ psi (normal weight concrete) <sup>4</sup>	$l_d$	ACI 318 12.2.3	mm (in.)	305 (12.0)	305 (12.0)	330 (13.0)	439 (17.3)	688 (27.1)	859 (33.8)	1100 (43.3)

For **SI**: 1 inch = 25.4 mm, 1 lbf = 4.448 N, 1 psi = 0.006897 Mpa  
 For **pound-inch** units: 1 mm = 0.03937 inches, 1 N = 0.2248 lbf, 1 Mpa = 145.0 psi

<sup>1</sup>Development lengths valid for static, wind, and earthquake loads (SDC A and B).  
<sup>2</sup>Development lengths in SDC C through F must comply with ACI 318-14 Chapter 18 or ACI 318-11 Chapter 21, as applicable, and section 4.2.4 of this report. The value of  $f_c$  used to calculate development lengths shall not exceed 2,500 psi for post-installed reinforcing bar applications in SDCs C, D, E, and F.  
<sup>3</sup>For all-lightweight concrete, increase development length by 33%, unless the provisions of ACI 318-14 25.4.2.4 or ACI 318-11 12.2.4 (d), as applicable, are met to permit  $\lambda > 0.75$ . For sand-lightweight concrete, increase development length by 18%, unless the provisions of ACI 318-14 25.4.2.4 or ACI 318-11 12.2.4 (d), as applicable, are met to permit  $\lambda > 0.85$ .  
<sup>4</sup> $\left(\frac{c_b + K_{tr}}{d_b}\right) = 2.5$ ,  $\psi_t = 1.0$ ,  $\psi_e = 1.0$ ,  $\psi_s = 0.8$  for  $d_b < 20$  mm, 1.0 for  $d_b \geq 20$  mm  
<sup>5</sup>Calculations may be performed for other steel grades per ACI 318-11 Chapter 12 or ACI 318-14 Chapter 25.  
<sup>6</sup>Minimum development length shall not be less than 12 in (305 mm) per ACI 318-14 Section 25.4.2.1

喜利得股份有限公司
送審專用
FOR REVIEW

**TABLE 18—DEVELOPMENT LENGTH FOR CANADIAN REINFORCING BARS IN HOLES DRILLED WITH A HAMMER DRILL AND CARBIDE BIT (OR HILTI HOLLOW CARBIDE BIT)<sup>1,2,3,5,6</sup>**

DESIGN INFORMATION	Symbol	Criteria Section of Reference Standard	Units	Bar Size				
				10M	15M	20M	25M	30M
Nominal reinforcing bar diameter	$d_b$	CAN/CSA-G30.18 Gr.400	mm (in.)	11.3 (0.445)	16.0 (0.630)	19.5 (0.768)	25.2 (0.992)	29.9 (1.177)
Nominal bar area	$A_b$	CAN/CSA-G30.18 Gr.400	mm <sup>2</sup> (in <sup>2</sup> )	100.3 (0.16)	201.1 (0.31)	298.6 (0.46)	498.8 (0.77)	702.2 (1.09)
Development length for $f_y = 58$ ksi and $f_c = 2,500$ psi (normal weight concrete) <sup>4</sup>	$l_d$	ACI 318 12.2.3	mm (in.)	315 (12.4)	445 (17.5)	678 (26.7)	876 (34.5)	1,041 (41.0)
Development length for $f_y = 58$ ksi and $f_c = 4,000$ psi (normal weight concrete) <sup>4</sup>	$l_d$	ACI 318 12.2.3	mm (in.)	305 (12.0)	353 (13.9)	536 (21.1)	693 (27.3)	823 (32.4)

For **SI**: 1 inch = 25.4 mm, 1 lbf = 4.448 N, 1 psi = 0.006897 Mpa  
 For **pound-inch** units: 1 mm = 0.03937 inches, 1 N = 0.2248 lbf, 1 Mpa = 145.0 psi

<sup>1</sup>Development lengths valid for static, wind, and earthquake loads (SDC A and B).  
<sup>2</sup>Development lengths in SDC C through F must comply with ACI 318-14 Chapter 18 or ACI 318-11 Chapter 21, as applicable, and section 4.2.4 of this report. The value of  $f_c$  used to calculate development lengths shall not exceed 2,500 psi for post-installed reinforcing bar applications in SDCs C, D, E, and F.  
<sup>3</sup>For all-lightweight concrete, increase development length by 33%, unless the provisions of ACI 318-14 25.4.2.4 or ACI 318-11 12.2.4 (d), as applicable, are met to permit  $\lambda > 0.75$ . For sand-lightweight concrete, increase development length by 17.6%, unless the provisions of ACI 318-14 25.4.2.4 or ACI 318-11 12.2.4 (d), as applicable, are met to permit  $\lambda > 0.85$ .  
<sup>4</sup> $\left(\frac{c_b+k_{tr}}{d_b}\right) = 2.5, \psi_t=1.0, \psi_e=1.0, \psi_s=0.8$  for  $d_b < 20$  mm, 1.0 for  $d_b \geq 20$  mm  
<sup>5</sup>Calculations may be performed for other steel grades per ACI 318-11 Chapter 12 or ACI 318-14 Chapter 25.  
<sup>6</sup>Minimum development length shall not be less than 12 in (305 mm) per ACI 318-14 Section 25.4.2.1



HILTI HIT-RE 100 FOIL PACK AND MIXING NOZZLE



HILTI DISPENSER



ANCHORING ELEMENTS



HILTI TE-CD OR TE-YD HOLLOW CARBIDE DRILL BIT

FIGURE 6—HILTI HIT-RE 100 ANCHORING SYSTEM

喜利得股份有限公司  
 送審專用  
 FOR REVIEW

**Specifications / Assumptions:**

ASTM A193 Grade B7 threaded rod  
 Normal weight concrete,  $f'_c = 4,000$  psi  
 Seismic Design Category (SDC) B  
 No supplementary reinforcing in accordance with ACI 318-14 2.3 will be provided.  
 Assume maximum short term (diurnal) base material temperature  $\leq 130^\circ$  F.  
 Assume maximum long term base material temperature  $\leq 110^\circ$  F.  
 Assume installation in dry concrete and hammer-drilled holes.  
 Assume concrete will remain uncracked for service life of anchorage.

**Dimensional Parameters:**

$h_{ef} = 9.0$  in.  
 $s = 4.0$  in.  
 $C_{a,min} = 2.5$  in.  
 $h = 12.0$  in.  
 $d = 1/2$  in.

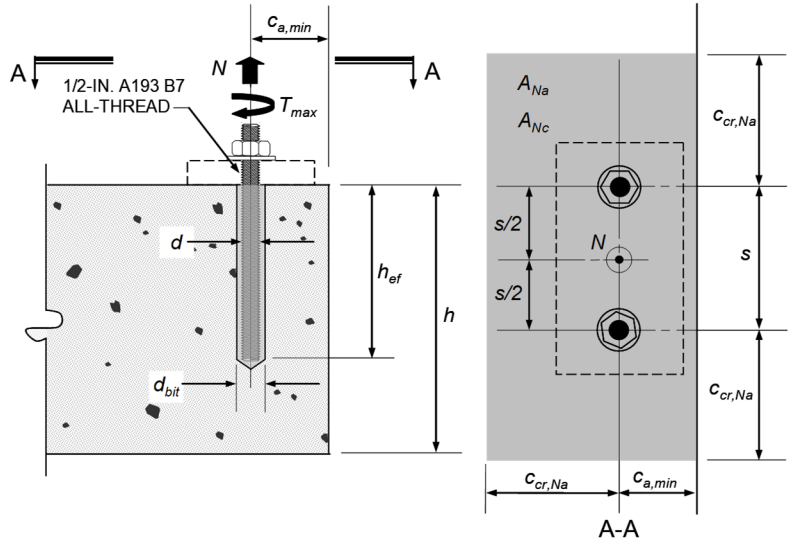

Calculation for the 2018 and 2015 IBC in accordance with ACI 318-14 Chapter 17 and this report	ACI 318-14 Code Ref.	Report Ref.
<p><b>Step 1. Check minimum edge distance, anchor spacing and member thickness:</b></p> <p><math>C_{min} = 2.5</math> in. <math>\leq C_{a,min} = 2.5</math> in. <math>\therefore</math> OK  <math>s_{min} = 2.5</math> in. <math>\leq s = 4.0</math> in. <math>\therefore</math> OK  <math>h_{min} = h_{ef} + 1.25</math> in. <math>= 9.0 + 1.25 = 10.25</math> in. <math>\leq h = 12.0</math> <math>\therefore</math> OK  <math>h_{ef,min} \leq h_{ef} \leq h_{ef,max} = 2.75</math> in. <math>\leq 9</math> in. <math>\leq 10</math> in. <math>\therefore</math> OK</p>	-	Table 6 Table 8
<p><b>Step 2. Check steel strength in tension:</b></p> <p>Single Anchor: <math>N_{sa} = A_{se} \cdot f_{uta} = 0.1419</math> in<sup>2</sup> <math>\cdot</math> 125,000 psi = 17,738 lb.                      Anchor Group: <math>\phi N_{sa} = \phi \cdot n \cdot A_{se} \cdot f_{uta} = 0.75 \cdot 2 \cdot 17,738</math> lb. = 26,606 lb.                      Or using Table 12: <math>\phi N_{sa} = 0.75 \cdot 2 \cdot 17,735</math> lb. = <b>26,603 lb.</b></p>	17.4.1.2 Eq. (17.4.1.2)	Table 2 Table 4
<p><b>Step 3. Check concrete breakout strength in tension:</b></p> <p><math>N_{cbg} = \frac{A_{Nc}}{A_{Nc0}} \cdot \psi_{ec,N} \cdot \psi_{ed,N} \cdot \psi_{c,N} \cdot \psi_{cp,N} \cdot N_b</math></p>	17.4.2.1 Eq. (17.4.2.1b)	-
<p><math>A_{Nc} = (3 \cdot h_{ef} + s)(1.5 \cdot h_{ef} + C_{a,min}) = (3 \cdot 9 + 4)(13.5 + 2.5) = 496</math> in<sup>2</sup></p>	-	-
<p><math>A_{Nc0} = 9 \cdot h_{ef}^2 = 729</math> in<sup>2</sup></p>	17.4.2.1 and Eq. (17.4.2.1c)	-
<p><math>\psi_{ec,N} = 1.0</math> no eccentricity of tension load with respect to tension-loaded anchors</p>	17.4.2.4	-
<p><math>\psi_{ed,N} = 0.7 + 0.3 \cdot \frac{C_{a,min}}{1.5h_{ef}} = 0.7 + 0.3 \cdot \frac{2.5}{1.5 \cdot 9} = 0.76</math></p>	17.4.2.5 and Eq. (17.4.2.5b)	-
<p><math>\psi_{c,N} = 1.0</math> uncracked concrete assumed (<math>k_{c,uncr} = 24</math>)</p>	17.4.2.6	Table 6
<p>Determine <math>C_{ac}</math>:                      From Table 8: <math>\tau_{uncr} = 1,256</math> psi  <math>\tau_{uncr} = \frac{k_{c,uncr}}{\pi \cdot d} \sqrt{h_{ef} \cdot f'_c} = \frac{24}{\pi \cdot 0.5} \sqrt{9.0 \cdot 4,000} = 2,899</math> psi <math>&gt;</math> 1,256 psi <math>\therefore</math> use 1,256 psi  <math>C_{ac} = h_{ef} \cdot \left(\frac{\tau_{uncr}}{1,160}\right)^{0.4} \cdot \left[3.1 - 0.7 \cdot \frac{h}{h_{ef}}\right] = 9 \cdot \left(\frac{1,256}{1,160}\right)^{0.4} \cdot \left[3.1 - 0.7 \cdot \frac{12}{9}\right] = 20.1</math> in</p>	-	Section 4.1.10 Table 8
<p>For <math>C_{a,min} &lt; C_{ac}</math> <math>\psi_{cp,N} = \frac{\max[C_{a,min}; 1.5 \cdot h_{ef}]}{C_{ac}} = \frac{\max[2.5; 15.9]}{20.1} = 0.67</math></p>	17.4.2.7 and Eq. (17.4.2.7b)	-
<p><math>N_b = k_{c,uncr} \cdot \lambda \cdot \sqrt{f'_c} \cdot h_{ef}^{1.5} = 24 \cdot 1.0 \cdot \sqrt{4,000} \cdot 9^{1.5} = 40,983</math> lb.</p>	17.4.2.2 and Eq. (17.4.2.2a)	Table 6
<p><math>N_{cbg} = \frac{496}{729} \cdot 1.0 \cdot 0.76 \cdot 1.0 \cdot 0.67 \cdot 40,983 = 14,233</math> lb.</p>	-	喜利得股份有限公司
<p><math>\phi N_{cbg} = 0.65 \cdot 14,233 = 9,252</math> lb.</p>	17.3.3(c)	Table 6

FIGURE 7—SAMPLE CALCULATION

喜利得股份有限公司  
 送審專用  
 FOR REVIEW

<p><b>Step 4. Check bond strength in tension:</b></p> $N_{ag} = \frac{A_{Na}}{A_{Na0}} \cdot \psi_{ec,Na} \cdot \psi_{ed,Na} \cdot \psi_{cp,Na} \cdot N_{ba}$	<p><b>17.4.5.1 Eq. (17.4.5.1b)</b></p>	-
$A_{Na} = (2C_{Na} + s)(C_{Na} + c_{a,min})$ $c_{Na} = 10d_a \sqrt{\frac{\tau_{uncr}}{1,100}} = 10d_a \sqrt{\frac{1,256}{1,100}} = 5.34 \text{ in}$ $A_{Na} = (2 \cdot 5.34 + 4)(5.34 + 2.5) = 115.2 \text{ in}^2$	<p><b>17.4.5.1 Eq. (17.4.5.1d)</b></p>	Table 8
$A_{Na0} = (2C_{Na})^2 = (2 \cdot 5.34)^2 = 114.2 \text{ in}^2$	<p><b>17.4.5.1 and Eq. (17.4.5.1c)</b></p>	-
$\psi_{ec,Na} = 1.0$ no eccentricity – loading is concentric	<p><b>17.4.5.3</b></p>	-
$\psi_{ed,Na} = \left(0.7 + 0.3 \cdot \frac{c_{a,min}}{c_{Na}}\right) = \left(0.7 + 0.3 \cdot \frac{2.5}{5.34}\right) = 0.84$	<p><b>17.4.5.4</b></p>	-
$\psi_{cp,Na} = \frac{\max  c_{a,min}; c_{Na} }{c_{ac}} = \frac{\max  2.5; 5.34 }{20.1} = 0.27$	<p><b>17.4.5.5</b></p>	-
$N_{ba} = \lambda \cdot \tau_{uncr} \cdot \pi \cdot d \cdot h_{ef} = 1.0 \cdot 1,256 \cdot \pi \cdot 0.5 \cdot 9.0 = 17,756 \text{ lb.}$	<p><b>17.4.5.2 and Eq. (17.4.5.2)</b></p>	Table 8
$N_{ag} = \frac{115.2}{114.2} \cdot 1.0 \cdot 0.84 \cdot 0.27 \cdot 17,756 = 3,995 \text{ lb.}$	-	-
$\phi N_{ag} = 0.65 \cdot 3,995 = 2,597 \text{ lb.}$	<p><b>17.3.3(c)</b></p>	Table 8
<p><b>Step 5. Determine controlling strength:</b></p> <p>Steel Strength <math>\phi N_{sa} = 26,603 \text{ lb.}</math></p> <p>Concrete Breakout Strength <math>\phi N_{cbg} = 9,252 \text{ lb.}</math></p> <p>Bond Strength <math>\phi N_{ag} = 2,597 \text{ lb. CONTROLS}</math></p>	<p><b>17.3.1</b></p>	-

FIGURE 7—SAMPLE CALCULATION (CONTINUED)

喜利得股份有限公司

送審專用

FOR REVIEW

**Specifications / Assumptions:**

**Development length for column starter bars**

Existing (E) construction:

Foundation grade beam 24 wide x 36-in deep., 4 ksi normal weight concrete, ASTM A615 Gr. 60 reinforcement

New (N) construction:

18 x 18-in. column as shown, centered on 24-in wide grade beam, 4 ksi normal weight concrete, ASTM A615 Gr. 60 reinforcement, 4 - #7 column bars, and #3 ties.

The column must resist moment and shear arising from wind loading.

**Dimensional Parameters:**

$$d_b = 0.875"$$

$$c_b = \frac{24" - 18"}{2} + 1.5" + 0.375" + \frac{0.875"}{2} = 5.3"$$

$$\frac{c_b + K_{tr}}{d_b} = \frac{5.3" + 0}{0.875"} = 6.1 \rightarrow \text{Use } 2.5 \text{ (} K_{tr} \text{ assumed to be 0)}$$

\*Note that the confinement term is limited to a maximum of 2.5 per ACI 318-14 Section 25.4.2.3

$$\psi_t = 1.0 \text{ (casting position)}$$

$$\psi_e = 1.0 \text{ (uncoated bars)}$$

$$\psi_s = 1.0 \text{ (bar is greater than a \#6)}$$

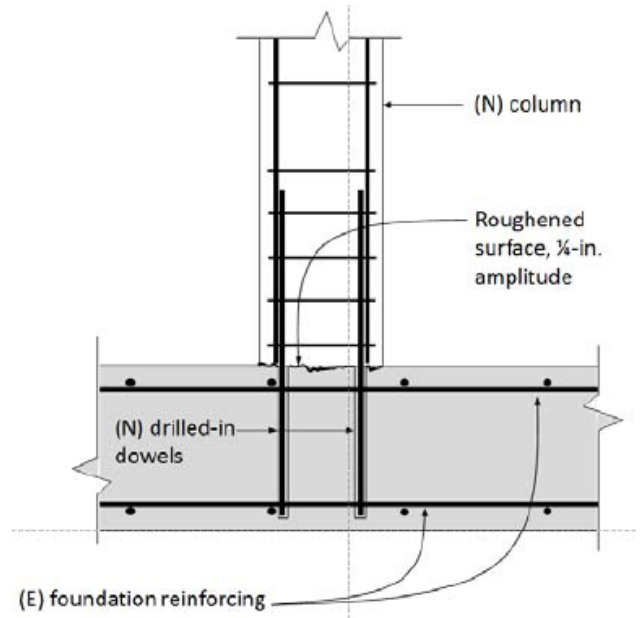

Calculation for the 2018 and 2015 IBC in accordance with ACI 318-14 Chapter 17 and this report.	ACI 318-14 Code Ref.
<p><b>Step 1. Determination of development length for the column bars:</b></p> $l_d = \left[ \frac{3}{40} \cdot \frac{f_y}{\lambda \cdot \sqrt{f'_c}} \cdot \frac{\psi_t \psi_e \psi_s}{c_b + K_{tr}} \right] \cdot d_b = \left[ \frac{3}{40} \cdot \frac{60000}{1.0 \cdot \sqrt{4000}} \cdot \frac{(1.0)(1.0)(1.0)}{2.5} \right] \cdot 0.875 = 25in.$	<p>Eq. (25.4.2.3a)</p>
<p><b>Step 2 Detailing (not to scale)</b></p>	

FIGURE 8—SAMPLE CALCULATION (POST-INSTALLED REINFORCING BARS)

喜利得股份有限公司  
送審專用  
FOR REVIEW

# HILTI

## HILTI HIT-RE 100

Instructions for use en

Instrucciones de uso es

Mode d'emploi fr

Instruções de utilização pt

**Danger**

Contains epoxy constituents. May produce an allergic reaction. (A)

**Contains:** reaction product: bisphenol-A-(epichlorohydrin) epoxy resin MW ≤ 700 (A), reaction product: bisphenol-F epichlorohydrin resin MW ≤ 700 (A), m-Xylenediamine, (B)

Causes severe skin burns and eye damage. (B)  
May cause an allergic skin reaction. (A, B)  
Toxic to aquatic life with long lasting effects. (A)

ICC-ES ESR - 3829

<b>en</b>	Hammer drilling	Hollow drill bit	
<b>es</b>	Taladrado con martillo	Taladro con broca hueca y aspiración	
<b>fr</b>	Perçage avec percussion	Foret creux	
<b>pt</b>	Perfurar de martelo	Broca de coroa oca	

<b>en</b>	Working time	Initial curing time	Curing time
<b>es</b>	Tiempo de tratamiento	Resistencia de montaje	Tiempo de fragu
<b>fr</b>	Temps de manipulation	Stabilité du montage	Temps de durcis
<b>pt</b>	Tempo de trabalho	Resistência de montagem	Tempo de cura

<b>en</b>	Dry concrete	Water saturated concrete	Waterfilled borehole in concrete
<b>es</b>	Hormigón seco	Hormigón saturado de agua	Taladro lleno de agua en hormigón
<b>fr</b>	Béton sec	Béton saturé d'eau	Trou dans le béton rempli d'eau
<b>pt</b>	Betão seco	Betão saturado de água	Furo em betão cheio de água

<b>en</b>	Threaded rod	Rebar	Uncracked concrete
<b>es</b>	Tige fileté	Armature métallique	Béton non lézardé
<b>fr</b>	Varilla roscada	Barras corrugadas para armado	Hormigón no fisurado
<b>pt</b>	Barra roscada	Ferros de armadura	Betão não fissurado

**HIT-V (-R, -F, -HGR) / HAS-E (-B) / HAS-R**

**HAS / HIT-V**

Ø d [inch]	Ø d <sub>o</sub> [inch]	h <sub>ef</sub> [inch]	Ø d <sub>i</sub> [inch]	T <sub>max</sub> [ft-lb]	T <sub>max</sub> [Nm]
3/8	7/16	2 3/8 ... 7 1/2	7/16	15	20
1/2	9/16	2 3/4 ... 10	9/16	30	41
5/8	3/4	3 1/8 ... 12 1/2	11/16	60	81
3/4	7/8	3 1/2 ... 15	13/16	100	136
7/8	1	3 1/2 ... 17 1/2	15/16	125	169
1	1 1/8	4 ... 20	1 1/8	150	203
1 1/4	1 3/8	5 ... 25	1 3/8	200	271

**HIT-V**

Ø d [mm]	Ø d <sub>o</sub> [mm]	h <sub>ef</sub> [mm]	Ø d <sub>i</sub> [mm]	T <sub>max</sub> [Nm]
M8	10	60...160	9	10
M10	12	60...200	12	20
M12	14	70...240	14	40
M16	18	80...320	18	80
M20	22	90...400	22	150
M24	28	96...480	26	200
M27	30	108...540	30	270
M30	35	120...600	33	300

1 inch = 25.4 mm

FIGURE 9—MANUFACTURER'S PRINTED INSTALLATION INSTRUCTIONS (MPII)

喜利得股份有限公司

送審專用

FOR REVIEW

Rebar

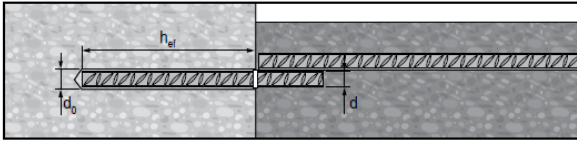

US Rebar

d	Ø d <sub>0</sub> [inch]	h <sub>ef</sub> [inch]
#3	1/2	2 3/8...22 1/2
#4	5/8	2 3/4...30
#5	3/4	3 1/8...37 1/2
#6	7/8	3 1/2...15
#7	1	15...45
	1	3 1/2...17 1/2
#8	1 1/8	17 1/2...52 1/2
	1 1/8	4...20
#9	1 1/4	20...60
	1 3/8	4 1/2...67 1/2
#10	1 1/2	5...75
#11	1 3/4	5 1/2...82 1/2

CA Rebar

d	Ø d <sub>0</sub> [inch]	h <sub>ef</sub> [mm]
10 M	3/16	70...678
15 M	3/4	80...960
20 M	1	90...1170
25 M	1 1/4 (32 mm)	101...1512
30 M	1 1/2	120...1794

EU Rebar

Ø d [mm]	Ø d <sub>0</sub> [mm]	h <sub>ef</sub> [mm]
8	12	60...480
10	14	60...600
12	16	70...720
14	18	75...840
16	20	80...960
18	22	85...1080
20	25	90...1200
22	28	95...1320
24	32	96...1440
25	32	100...1500
26	35	104...1560
28	35	112...1680
30	37	120...1800
32	40	128...1920

[°C]	[°F]	t <sub>work</sub>	t <sub>cure, ini</sub>	t <sub>cure, full</sub>
10	50	2 h	≥ 12 h	≥ 48 h
15	59	1 1/2 h	≥ 8 h	≥ 24 h
20	68	30 min	≥ 6 h	≥ 12 h
30	86	20 min	≥ 4 h	≥ 8 h
40	104	12 min	≥ 2 h	≥ 4 h

**Rebar - h<sub>ef</sub> ≥ 20d**

	h <sub>ef</sub>		
HDM, HDE, HIT-P 8000D	≤ US #5	12 1/2 ... 37 1/2 [inch]	23 °F ... 104 °F / -5 °C ... 40 °C
	≤ EU 16mm	320 ... 960 [mm]	
	≤ CAN 15M	320 ... 960 [mm]	
HDE, HIT-P 8000D	≤ US #7	17 1/2 ... 52 1/2 [inch]	23 °F ... 104 °F / -5 °C ... 40 °C
	≤ EU 20mm	400 ... 1200 [mm]	
	≤ CAN 20M	390 ... 1170 [mm]	
HIT-P 8000D	≤ US #10	25 ... 75 [inch]	23 °F ... 104 °F / -5 °C ... 40 °C
	≤ EU 32mm	640 ... 1920 [mm]	
	≤ CAN 30M	598 ... 1794 [mm]	

	h <sub>ef</sub>		
HDM, HDE, HIT-P 8000D	≤ US #5	12 1/2 ... 37 1/2 [inch]	23 °F ... 104 °F / -5 °C ... 40 °C
	≤ EU 16mm	320 ... 960 [mm]	
	≤ CAN 15M	320 ... 960 [mm]	
HDE, HIT-P 8000D	≤ US #7	17 1/2 ... 39 3/8 [inch]	23 °F ... 104 °F / -5 °C ... 40 °C
	≤ EU 20mm	400 ... 1000 [mm]	
	≤ CAN 20M	390 ... 1000 [mm]	

Ø	Ø	HAS/HIT-V	Rebar	HIT-RB	HIT-SZ	HIT-DL	HIT-OHC
d <sub>0</sub> [inch]	d <sub>0</sub> [inch]	d [inch]	d [inch]	[inch]	[inch]	[inch]	Art. No.
7/16	-	3/8	-	7/16	-	-	387551
1/2	1/2	-	#3	1/2	1/2	1/2	
9/16	9/16	1/2	10M	9/16	9/16	9/16	
5/8	5/8	-	#4	5/8	5/8	9/16	
3/4	3/4	5/8	15M #5	3/4	3/4	3/4	
7/8	7/8	3/4	#6	7/8	7/8	7/8	
1	1	7/8	20M #7	1	1	1	387552
1 1/8	1 1/8	1	#8	1 1/8	1 1/8	1	
1 1/4	-	-	25M	1 1/4	1 1/4	1	
1 3/8	-	1 1/4	#9	1 3/8	1 3/8	1 3/8	
1 1/2	-	-	30M #10	1 1/2	1 1/2	1 3/8	

HIT-DL: h<sub>ef</sub> > 10" HIT-RB: h<sub>ef</sub> > 20 x d

HIT-RE-M	HIT-OHW
Art. No.	Art. No.
337111	387550

d <sub>0</sub> [inch]	[inch]	Art. No. 381215	≥ 6 bar/90 psi @ 6 m³/h / ≥ 140 m³/h / ≥ 82 CFM
7/16" ... 1 1/8"	2 3/8" ... 20"	✓	
1 1/4" ... 1 1/2"	4" ... 25"	-	

Ø	Ø	HIT-V	Rebar	HIT-RB	HIT-SZ	HIT-DL	HIT-OHC
d <sub>0</sub> [mm]	d <sub>0</sub> [mm]	d [mm]	d [mm]	[mm]	[mm]	[mm]	Art. No.
10	-	8	-	10	-	-	387551
12	12	10	8	12	12	12	
14	14	12	10	14	14	14	
16	16	-	12	16	16	16	
18	18	16	14	18	18	18	
20	20	-	16	20	20	20	
22	22	20	18	22	22	20	
25	25	-	20	25	25	25	
28	28	24	22	28	28	25	
30	-	27	-	30	30	25	387552
32	32	-	24/25	32	32	32	
35	35	30	26/28	35	35	32	
37	-	-	30	37	37	32	
40	-	-	32	40	40	32	

HIT-DL: h<sub>ef</sub> > 250 mm HIT-RB: h<sub>ef</sub> > 20 x d

HIT-RE-M	HIT-OHW
Art. No.	Art. No.
337111	387550

d <sub>0</sub> [mm]	[mm]	Art. No. 381215	≥ 6 bar/90 psi / ≥ 140 m³/h
10...32	60...500	✓	
35...40	100...640	-	

限公司

送審專用

FIGURE 9—MANUFACTURER'S PRINTED INSTALLATION INSTRUCTIONS (MPII) (CONTINUED)

IEW



喜利得股份有限公司  
**送審專用**  
**FOR REVIEW**

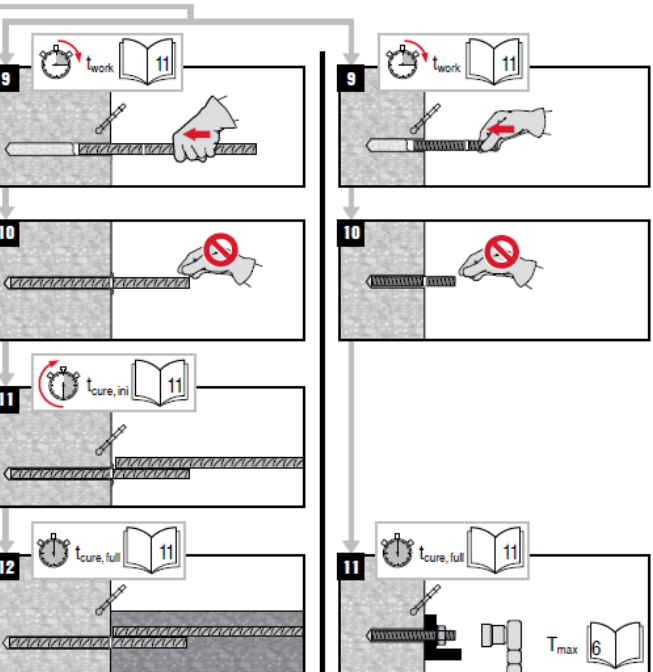
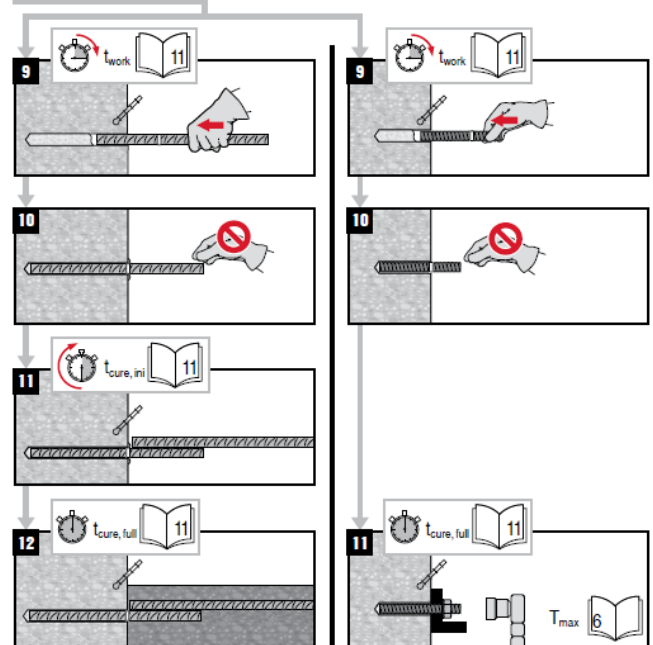
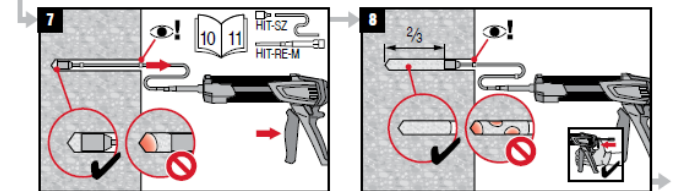
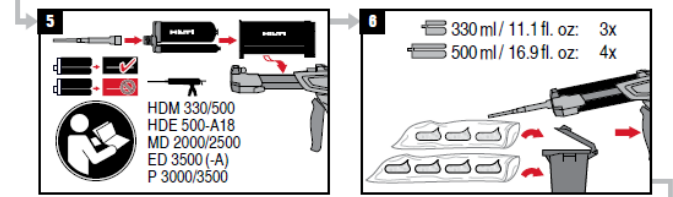
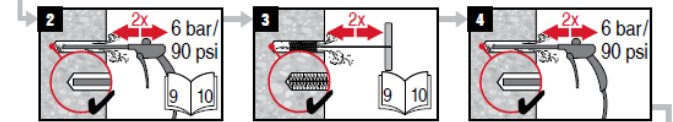
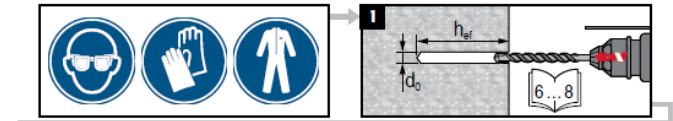
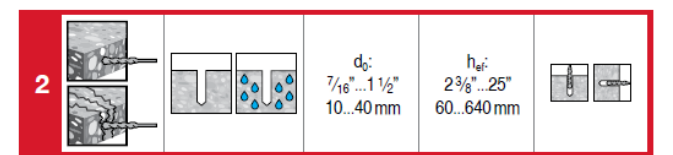
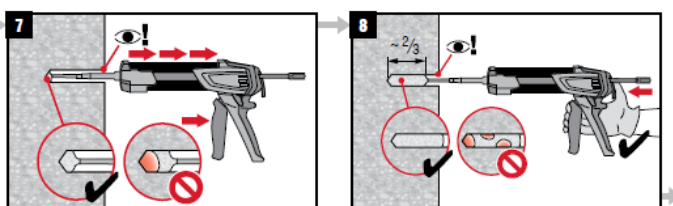
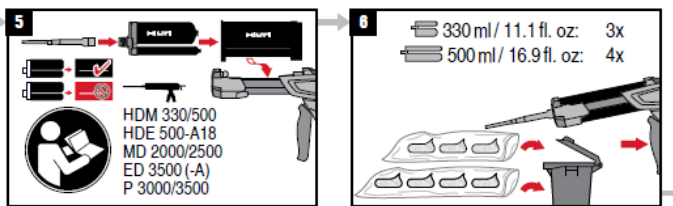
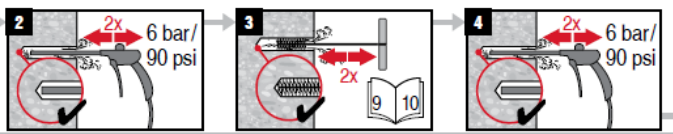
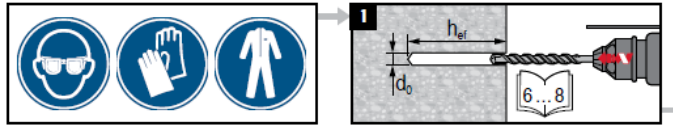
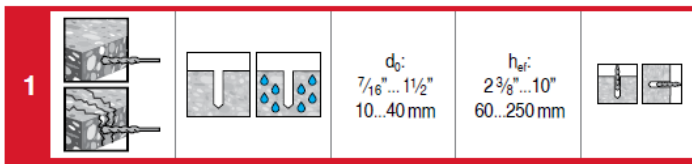

FIGURE 9—MANUFACTURER'S PRINTED INSTALLATION INSTRUCTIONS (MPII) (CONTINUED)

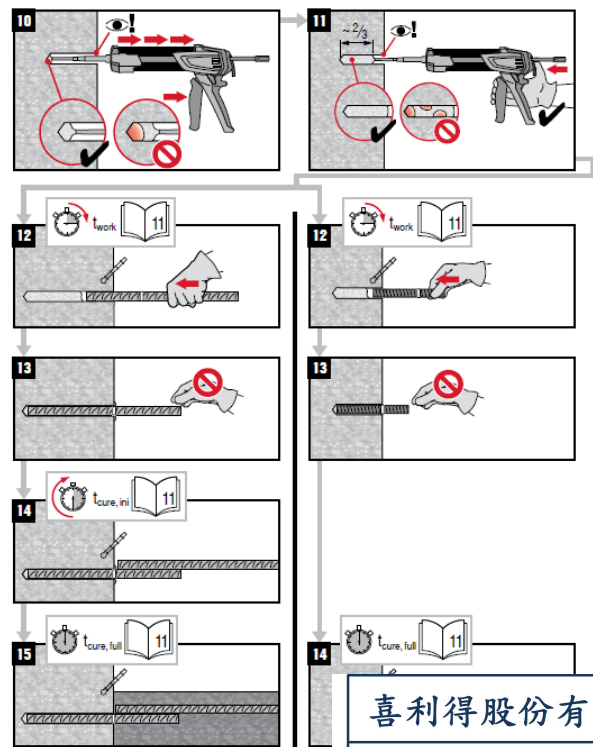
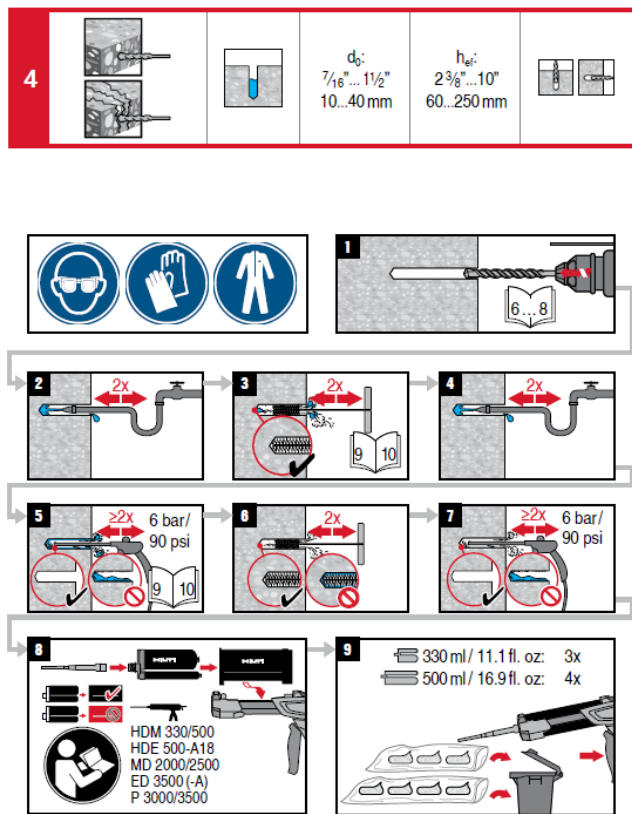
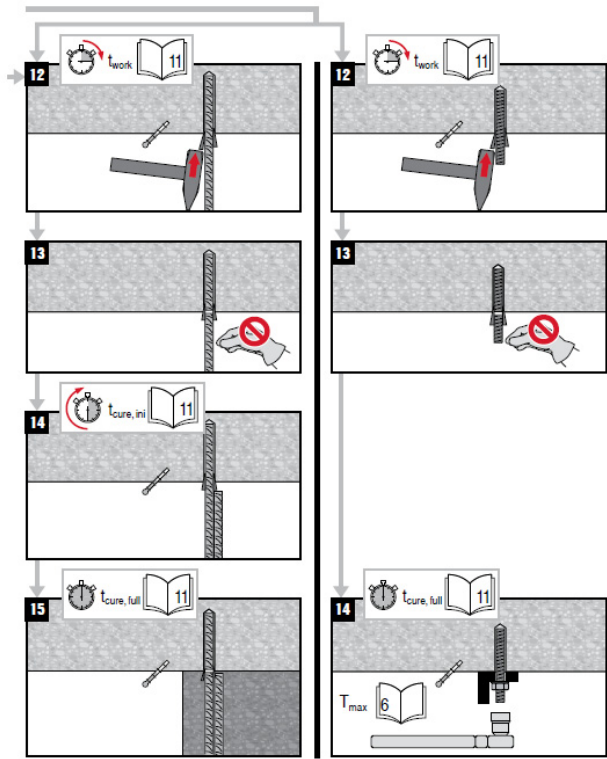
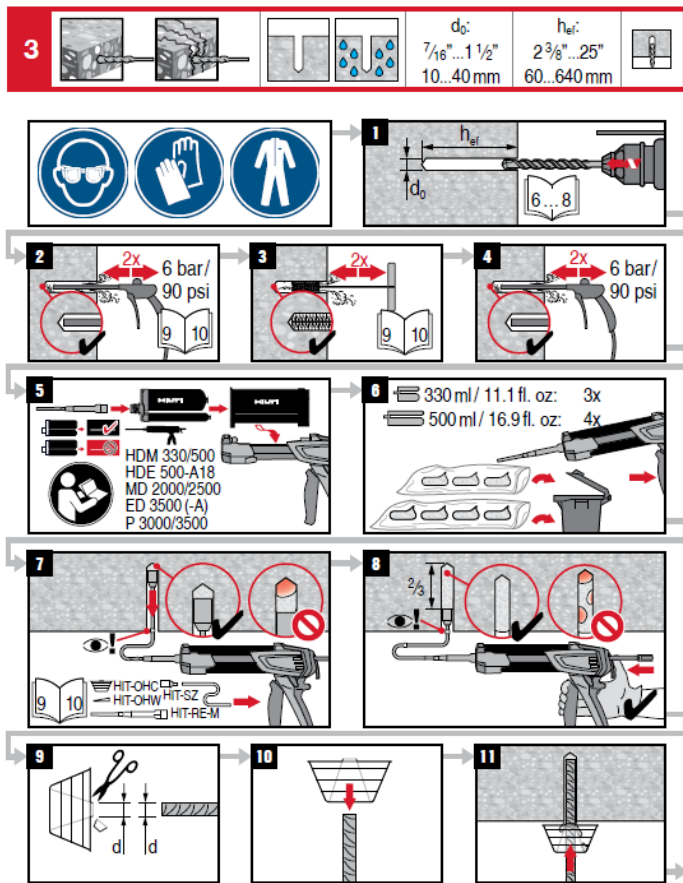

FIGURE 9—MANUFACTURER'S PRINTED INSTALLATION INSTRUCTIONS (MPII) (CONT)

喜利得股份有限公司  
送審專用  
FOR REVIEW

**5**

$d_0$ : 7/16" ... 1 1/2"  
10...40 mm

$h_{ef}$ : 2 3/8" ... 25"  
60...640 mm

**1** 6...8

**2** 2x

**3** 2x

**4** 2x

**5**  $\geq 2x$  6 bar / 90 psi

**6** 2x

**7**  $\geq 2x$  6 bar / 90 psi

**8** HDM 330/500  
HDE 500-A18  
MD 2000/2500  
ED 3500 (-A)  
P 3000/3500

**9** 330 ml / 11.1 fl. oz.: 3x  
500 ml / 16.9 fl. oz.: 4x

**6**

$d_0$ : 7/16" ... 1 1/2"  
10...40 mm

$h_{ef}$ : 2 3/8" ... 25"  
60...640 mm

**1**  $h_{ef}$ ,  $d_0$  6...8

**2** 2x

**3** 2x

**4** 2x

**5** HDM 330/500 ✓  
HDE 500-A18 ✓  
MD 2000/2500 ✓  
ED 3500 (-A) ✗  
P 3000/3500 ✗

**6** 330 ml / 11.1 fl. oz.: 3x  
500 ml / 16.9 fl. oz.: 4x

**7** HIT-SZ, HIT-REM

**8** 100%

**7** HIT-SZ, HIT-REM

**8** 2/3

**12**  $t_{work}$  11

**13** ✗

**14**  $t_{cure, ini}$  11

**15**  $t_{cure, full}$  11

**14**  $t_{cure, full}$  11,  $T_{max}$  6

喜利得股份有限公司  
送審專用  
FOR REVIEW

**9**  $t_{work}$  11

**10** ✗

**11**  $t_{cure, ini}$  11

**12**  $t_{cure, full}$  11

**11**  $t_{cure, full}$  11,  $T_{max}$  6

FIGURE 9—MANUFACTURER'S PRINTED INSTALLATION INSTRUCTIONS (MPII) (CONTINUED)

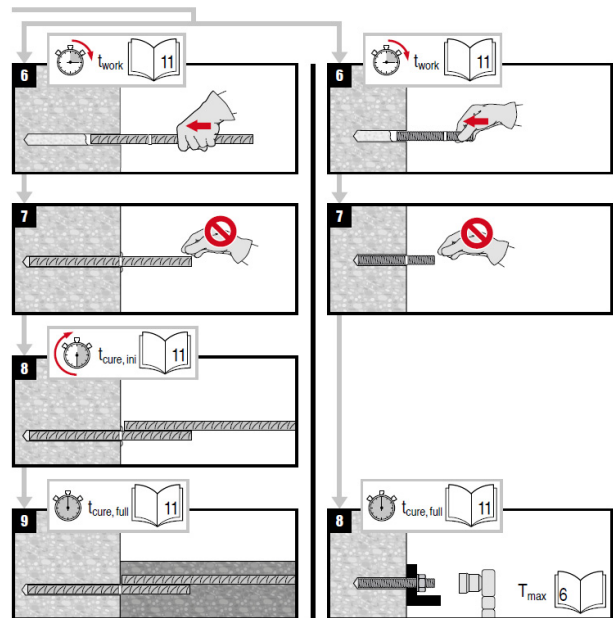
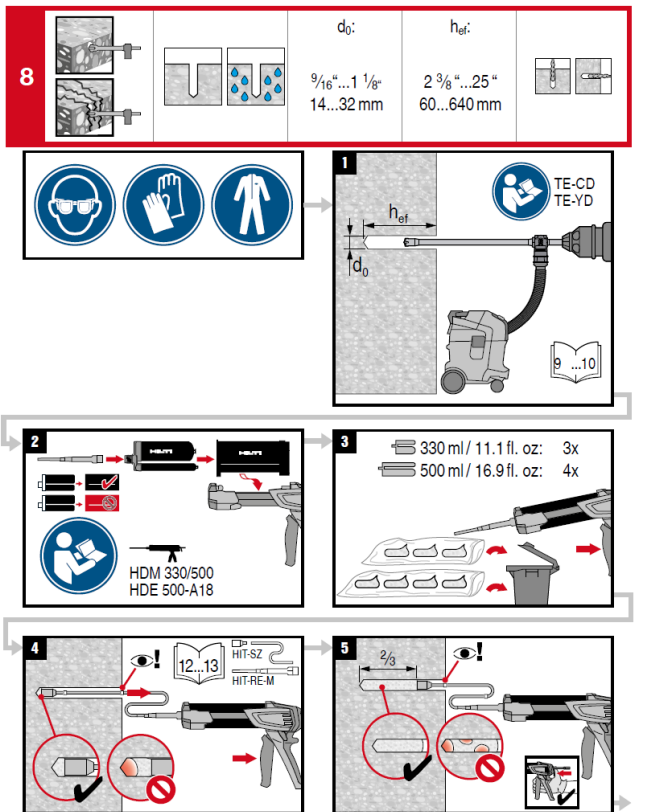
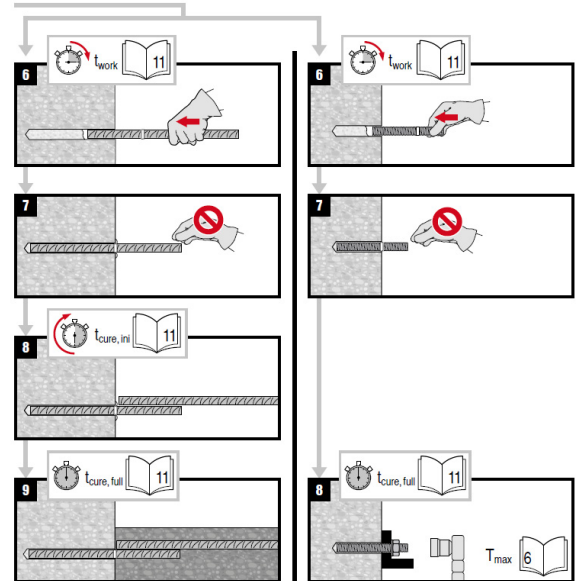
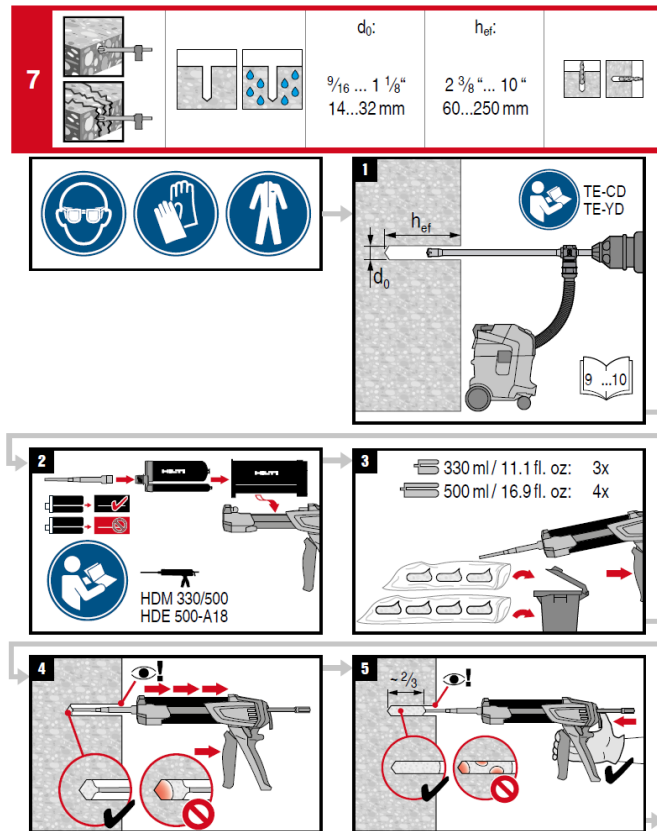
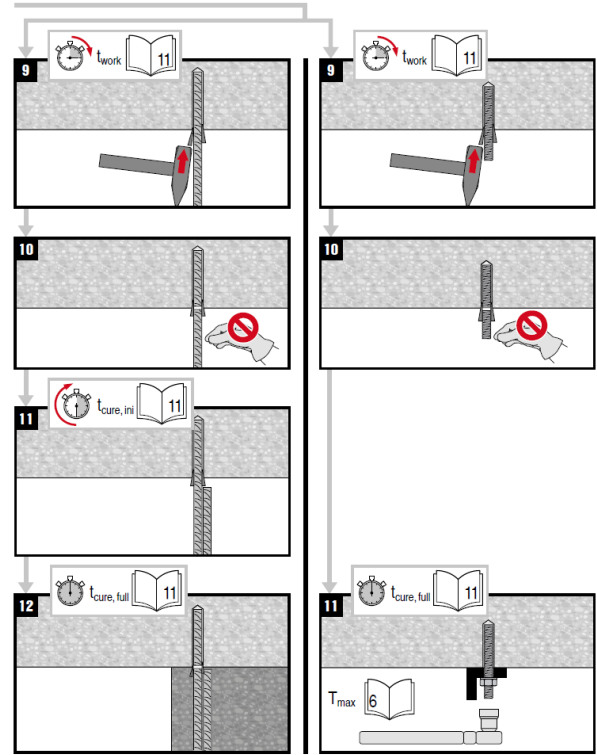
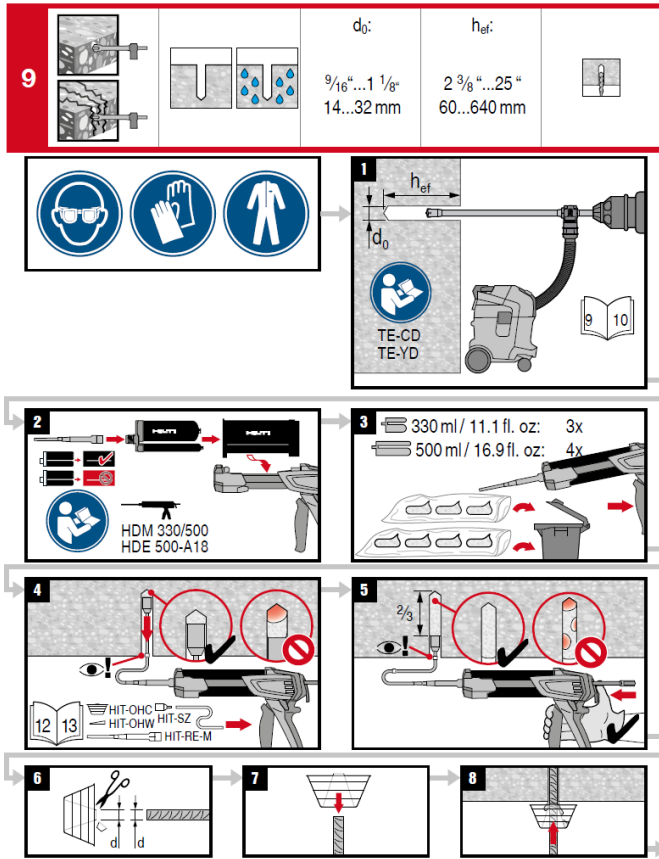

FIGURE 9—MANUFACTURER'S PRINTED INSTALLATION INSTRUCTIONS (MPII) (CONTINUED)

送審專用  
FOR REVIEW



**Adhesive anchoring system for rebar and anchor fastenings in concrete**

- Prior to use of product, follow the instructions for use and the legally obligated safety precautions.
- See the Safety Data Sheet for this product.

**Hilti HIT-RE 100**  
 Contains epoxy constituents. May produce an allergic reaction.(A)  
**Contains:** reaction product: bisphenol-A-(epichlorhydrin) epoxy resin MW ≤ 700 (A), reaction product: bisphenol-F epichlorhydrin resin MWs700 (A), m-xylenediamine.(B)

**Danger**

(B)	(A,B)	(A)
H314	H317	H411
Causes severe skin burns and eye damage.(B)		
May cause an allergic skin reaction.(A,B)		
Toxic to aquatic life with long lasting effects.(A)		
P280	Wear protective gloves/protective clothing/eye protection/face protection.	
P260	Do not breathe vapours.	
P303+P361+P353	IF ON SKIN (or hair): Remove/Take off immediately all contaminated clothing. Rinse skin with water/shower.	
P305+P351+P338	IF IN EYES: Rinse cautiously with water for several minutes. Remove contact lenses, if present and easy to do. Continue rinsing.	
P333+P313	If skin irritation or rash occurs: Get medical advice/attention.	
P337+P313	If eye irritation persists: Get medical advice/attention.	

**Recommended protective equipment:**

- **Eye protection:** Tightly sealed safety glasses e.g.: #02065449 Safety glasses PP EY-GA NCH clear; #02065591 Goggles PP EY-HA R HC/AF clear;
  - **Protective gloves:** EN 374 ; Material of gloves: Nitrile rubber, NBR
- Avoid direct contact with the chemical/ the product/ the preparation by organizational measures.  
**Final selection of appropriate protective equipment is in the responsibility of the user**

**Disposal considerations**

**Empty packs:**

- Leave the Mixer attached and dispose of via the local Green Dot collecting system or EAK waste material code 15 01 02 plastic packaging.

**Full or partially emptied packs:**

- dispose of as special waste in accordance with official regulations.
  - EAK waste material code: 20 01 27\* paint, inks, adhesives and resins containing dangerous substances.
  - or waste material code: EAK 08 04 09\* waste adhesives and sealants containing organic solvents or other dangerous substances.

<b>Content:</b>	330 ml / 11.1 fl.oz	500 ml / 16.9 fl.oz
<b>Weight:</b>	480 g / 16.9 oz	727 g / 25.6 oz

**Warranty:** Refer to standard Hilti terms and conditions of sale for warranty information.

Failure to observe these installation instructions, use of non-Hilti anchors, poor or questionable concrete conditions, or unique applications may affect the reliability or performance of the fastenings.

**Product Information**

- Always keep this instruction for use together with the product.
- Ensure that the instruction for use is with the product when it is given to other persons.
- **Safety Data Sheet:** Review the SDS before use.
- **Check expiration date:** See expiration date imprint on foil pack manifold (month/year). Do not use expired product.
- **Foil pack temperature during usage:** +5 °C to 40 °C / 41 °F to 104 °F.
- **Conditions for transport and storage:** Keep in a cool, dry and dark place between +5 °C to 25 °C / 41 °F to 77 °F.
- For any application not covered by this document / beyond values specified, please contact Hilti.
- **Partly used foil packs must be used up within 4 weeks.** Leave the mixer attached on the foil pack manifold and store under the recommended storage conditions. If reused, attach a new mixer and discard the initial quantity of anchor adhesive.

**WARNING**

- ! **Improper handling may cause mortar splashes. Eye contact with mortar may cause irreversible eye damage!**
  - Always wear lightly sealed safety glasses, gloves and protective clothes before handling the mortar
  - Never start dispensing without a mixer properly screwed on.
  - Attach a new mixer prior to dispensing a new foil pack (snug fit).
  - Caution! Never remove the mixer while the foil pack system is under pressure. Press the release button of the dispenser to avoid mortar splashing.
  - Use only the type of mixer supplied with the adhesive. Do not modify the mixer in any way.
  - Never use damaged foil packs and/or damaged or unclean foil pack holders.
- ! **Poor load values / potential failure of fastening points due to inadequate borehole cleaning. The boreholes must be dry and free of debris, dust, water, ice, oil, grease and other contaminants prior to adhesive injection.**
  - For blowing out the borehole - blow out with oil free air until return air stream is free of noticeable dust.
  - For flushing the borehole - flush with water line pressure until water runs clear.
  - Important! Remove all water from the borehole and blow out with oil free compressed air until borehole is completely dried before mortar injection (not applicable to hammer drilled hole in underwater application).
- ! **Ensure that boreholes are filled from the back of the boreholes without forming air voids.**
  - If necessary, use the accessories / extensions to reach the back of the borehole.
  - For overhead applications use the overhead accessories HIT-SZ / IP and take special care when inserting the fastening element. Excess adhesive may be forced out of the borehole. Make sure that no mortar drips onto the installer.
  - If a new mixer is installed onto a previously-opened foil pack, the first trigger pulls must be discarded.
  - A new mixer must be used for each new foil pack.

喜利得股份有限公司

FIGURE 9—MANUFACTURER’S PRINTED INSTALLATION INSTRUCTIONS (MPII) (CONTINUED)

送審專用

FOR REVIEW

**DIVISION: 03 00 00—CONCRETE**  
**Section: 03 16 00—Concrete Anchors**

**DIVISION: 05 00 00—METALS**  
**Section: 05 05 19—Post-Installed Concrete Anchors**

**REPORT HOLDER:**

HILTI, INC.

**EVALUATION SUBJECT:**

**HILTI HIT-RE 100 ADHESIVE ANCHORS AND POST INSTALLED REINFORCING BAR CONNECTIONS IN CRACKED AND UNCRACKED CONCRETE**

**1.0 REPORT PURPOSE AND SCOPE**

**Purpose:**

The purpose of this evaluation report supplement is to indicate that the Hilti HIT-RE 100 Adhesive Anchoring System and Post-Installed Reinforcing Bar System, described in ICC-ES evaluation report [ESR-3829](#), have also been evaluated for compliance with the codes noted below as adopted by Los Angeles Department of Building and Safety (LADBS).

**Applicable code editions:**

- 2020 *City of Los Angeles Building Code* (LABC)
- 2020 *City of Los Angeles Residential Code* (LARC)

**2.0 CONCLUSIONS**

The Hilti HIT-RE 100 Adhesive Anchoring System and Post-Installed Reinforcing Bar System, described in Sections 2.0 through 7.0 of the evaluation report [ESR-3829](#), comply with LABC Chapter 19, and LARC, and are subject to the conditions of use described in this report.

**3.0 CONDITIONS OF USE**

The Hilti HIT-RE 100 Adhesive Anchoring System and Post-Installed Reinforcing Bar System described in this evaluation report supplement must comply with all of the following conditions:

- All applicable sections in the evaluation report [ESR-3829](#).
- The design, installation, conditions of use and labeling of the anchors are in accordance with the 2018 *International Building Code*® (2018 IBC) provisions noted in the evaluation report [ESR-3829](#).
- The design, installation and inspection are in accordance with additional requirements of LABC Chapters 16 and 17, as applicable.
- Under the LARC, an engineered design in accordance with LARC Section R301.1.3 must be submitted.
- The allowable and strength design values listed in the evaluation report and tables are for the connection of the anchors to the concrete. The connection between the anchors and the connected members shall be checked for capacity (which may govern).
- For use in wall anchorage assemblies to flexible diaphragm, anchors shall be designed per the requirements of City of Los Angeles Information Bulletin P/BC 2020-071.

This supplement expires concurrently with the evaluation report, reissued April 2020.

喜利得股份有限公司
送審專用
FOR REVIEW

**DIVISION: 03 00 00—CONCRETE**  
**Section: 03 16 00—Concrete Anchors**

**DIVISION: 05 00 00—METALS**  
**Section: 05 05 19—Post-Installed Concrete Anchors**

**REPORT HOLDER:**

HILTI, INC.

**EVALUATION SUBJECT:**

**HILTI HIT-RE 100 ADHESIVE ANCHORS AND POST INSTALLED REINFORCING BAR CONNECTIONS IN CRACKED AND UNCRACKED CONCRETE**

**1.0 REPORT PURPOSE AND SCOPE**

**Purpose:**

The purpose of this evaluation report supplement is to indicate that the Hilti HIT-RE 100 Adhesive Anchoring System, recognized in ICC-ES evaluation report ESR-3829, has also been evaluated for compliance with the codes noted below.

**Applicable code editions:**

- 2017 *Florida Building Code—Building*
- 2017 *Florida Building Code—Residential*

**2.0 CONCLUSIONS**

The Hilti HIT-RE 100 Adhesive Anchoring System, described in Sections 2.0 through 7.0 of the evaluation report ESR-3829, complies with the *Florida Building Code—Building* and the *Florida Building Code—Residential*, provided the design and installation are in accordance with the 2015 *International Building Code*® provisions noted in the evaluation report.

Use of the Hilti HIT-RE 100 Adhesive Anchoring System has also been found to be in compliance with the High-Velocity Hurricane Zone provisions of the *Florida Building Code—Building* and the *Florida Building Code—Residential*.

For products falling under Florida Rule 9N-3, verification that the report holder’s quality-assurance program is audited by a quality-assurance entity approved by the Florida Building Commission for the type of inspections being conducted is the responsibility of an approved validation entity (or the code official, when the report holder does not possess an approval by the Commission).

This supplement expires concurrently with the evaluation report, reissued April 2020.

喜利得股份有限公司  
送審專用  
FOR REVIEW





## 附件二 HILTI HIT-RE100 原廠型錄





# HIT-RE 100

化學藥劑最佳的植筋伙伴

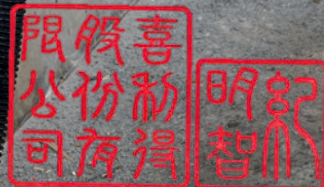

喜利得股份有限公司

送審專用

FOR REVIEW

# 化學藥劑最佳的植筋伙伴

HIT-RE 100  
化學藥劑系統

## 應用與優勢

- 後置植筋應用
- 連接重型鋼結構 (例如: 鋼柱、鋼樑)
- 提供完整的錨栓系統, 包括HAS-T螺桿 (鍍鋅)、HAS-T-R2螺桿 (不鏽鋼)
- 適用於各種直徑的螺桿或鋼筋及埋深
- 通過ICC認證、AC308標準, 適用於開裂與未開裂混凝土
- 經過ASTM D570 168小時吸水率與ASTM C882握裹力測試
- 取得NSF/ANSI 61認證, 可安全使用於飲用水系統
- 配合使用電動注射器可準確控制用量, 大大提升施工效率
- 適用各種鑽孔條件, 包括含水孔和水下施工
- 德國原廠進口, 原廠完整服務



### 技術資料

材料	兩劑型藥劑
基材溫度	5-40度
鋼筋/螺桿直徑	#3-#11/M10-M30
國際認證/規範	美國ICC-ES ESR-3829 (化學錨栓、後置植筋) 歐洲ETA-15/0882化學錨栓 歐洲ETA-15/0883後置植筋 EAD330087-00-0601通過鋼筋抗腐蝕測試 AC308標準, 適用於開裂與未開裂混凝土

### 工作/硬化時間表

基材溫度	工作時間	硬化時間
5°C	2.5小時	≥72小時
10°C	2小時	≥48小時
15°C	1.5小時	≥24小時
20°C	30分鐘	≥12小時
30°C	20分鐘	≥8小時
40°C	12分鐘	≥4小時



適用於混凝土基材



取得美國國際規範協會 (AC308) 認證報告



建築防火認證報告



ETA通過鋼筋抗腐蝕測試



歐盟技術認證報告



通過美國綠建築協會認證



歐盟認證產品標章



可使用喜利得錨栓設計軟體

## 後置植筋資料表

鋼筋	換算直徑	鑽孔直徑(mm)	鑽頭	電鍍鑽	鋼筋強度(kgf/cm <sup>2</sup> )	鋼筋降伏強度(kgf)	拉拔降伏埋深(mm)
#3	D10	12-14	TE/CX 12	TE 2-TE 30	2800/4200	1988/2982	80/120
#4	D13	16-18	TE/CX 16	TE 30	2800/4200	3556/5334	110/165
#5	D16	20-22	TE/YX 20	TE 50	2800/4200	5572/8358	145/215
#6	D19	25-28	TE/YX 25	TE 50	4200	12054	265
#7	D22	28-30	TE/YX 28	TE 70	4200	16254	320
#8	D25	32-35	TE/YX 32	TE 70	4200	21294	375
#9	D29	35-37	TE/YX 35	TE 70	4200	27174	430
#10	D32	40	TE/YX 40	TE 70	4200	34188	500

### 備註:

- 上表植筋的數據參考認證報告ICC ESR-3829, 混凝土為乾燥非開裂混凝土, 強度 $f'_c=280\text{kgf/cm}^2$ , 植筋深度安全係數為1.25。
- 化學藥劑考量受基材溫度、鋼筋間邊距、施工環境、鑽孔方式及孔壁狀態, 將影響實際施工成果表現。
- 如個案需植筋深度之結構計算或現場需要安排施工指導, 請撥免費服務專線0800-221036洽喜利得工程部。

## 化錨技術資料表

螺桿尺寸	基本埋深(mm)	基材最小厚度(mm)	鑽孔直徑(mm)	5.8級螺桿特性拉力(kgf)	5.8級螺桿特性剪力(kgf)	設計拉力(kgf)	設計剪力(kgf)
M8	80	110	10	1886	1122	1040	673
M10	90	120	12	2957	1479	1463	887
M12	110	140	14	4283	2600	2121	1560
M16	125	165	18	8005	4793	3066	2876
M20	170	220	22	12492	7495	5023	4497
M24	210	270	28	17998	10809	7260	6485

### 備註:

- 上表化錨的容許載重是依據ICC認證ESR-3829之強度設計參數, 及根據ACI 318-14第17章之公式計算出。
- 混凝土為乾燥非開裂混凝土, 強度 $f'_c=280\text{kgf/cm}^2$
- 詳細計算資料請參考喜利得最新技術手冊或洽喜利得工程部。

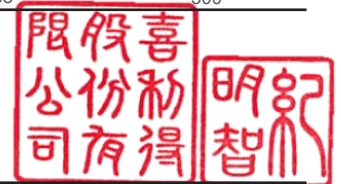

喜利得股份有限公司  
www.hilti.com.tw  
twcs@hilti.com

喜利得股份有限公司

送審專用

客服專線 0800-221-036  
傳真 02-5030-0347

FOR REVIEW

更多RE100產品資訊



## 附件三 材料廠商公司資料



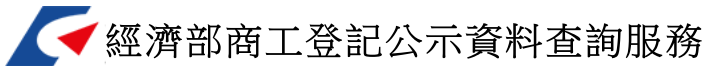

## 公司基本資料

統一編號	22348814
公司狀況	核准設立
股權狀況	僑外資
公司名稱	喜利得股份有限公司
章程所訂外文公司名稱	Hilti Taiwan Company Ltd.
資本總額(元)	170,000,000
實收資本額(元)	110,000,000
每股金額(元)	100
已發行股份總數(股)	1,100,000
代表人姓名	Laurent Camille Gimenez
公司所在地	新北市板橋區新站路16號24樓 電子地圖
登記機關	新北市政府
核准設立日期	075年12月31日
最後核准變更日期	109年07月17日
複數表決權特別股	無
對於特定事項具否決權特別股	無
特別股股東被選為董事、監察人之禁止或限制或當選一定名額之權利	無

所營事業資料

F106010 五金批發業  
 F107170 工業助劑批發業  
 F107990 其他化學製品批發業  
 F113010 機械批發業  
 F113020 電器批發業  
 F113030 精密儀器批發業  
 F113060 度量衡器批發業  
 F120010 耐火材料批發業  
 F206010 五金零售業  
 F207170 工業助劑零售業  
 F207990 其他化學製品零售業  
 F213080 機械器具零售業  
 F213010 電器零售業  
 F213040 精密儀器零售業  
 F213050 度量衡器零售業  
 F220010 耐火材料零售業  
 F401010 國際貿易業  
 F401021 電信管制射頻器材輸入業  
 E903010 防蝕、防銹工程業  
 EZ99990 其他工程業  
 JA02010 電器及電子產品修理業  
 JE01010 租賃業  
 I301010 資訊軟體服務業  
 I301030 電子資訊供應服務業  
 ZZ99999 除許可業務外，得經營法令非禁止或限制之業務



喜利得股份有限公司

送審專用

FOR REVIEW

# 新北市政府 函

機關地址：22001新北市板橋區中山路1段  
161號3樓  
承辦人：林梅蕙（603）  
電話：(02)29603456轉5289  
傳真：(02)29568030  
電子郵件：AE9557@ntpc.gov.tw

105  
臺北市松山區敦化北路168號15樓

受文者：喜利得股份有限公司代理人：馬靜如律師

發文日期：中華民國109年07月17日  
發文字號：新北府經司字第1098050134號  
速別：普通件  
密等及解密條件：普通  
附件：規費收據暨變更登記表1份

主旨：貴公司（統一編號：22348814）申請法人股東改派代表人為董事、補選Laurent Camille Gimenez為董事長、委任盧俊文為經理人、經理人解任變更登記，經核符合規定，准予登記。

說明：

- 一、依公司法辦理兼復貴公司109年07月15日補正（收文日）申請書。
- 二、處分相對人名稱：喜利得股份有限公司（代表人姓名：Laurent Camille Gimenez、身分證照號碼：13BC8\*\*\*\*）、公司所在地：新北市板橋區新站路16號24樓。
- 三、檢附規費收據暨變更登記表1份，請查收。
- 四、依公司法第22條-1規定，除外商公司、公開發行股票公司及國營事業外，公司應檢視本次變更若有董事、監察人、經理人及持有已發行股份總數或資本總額超過百分之十之股東等申報資料如有變動，公司應於變動後15日內前往「公司負責人及主要股東資訊申報平臺」（網址：<https://ctp.tdcc.com.tw>）執行變動申報。未依規定完成申報或申報不實之公司，經限期通知改正仍未改正者，可處新臺幣5~500萬元罰鍰，最重將可廢止公司登記。申報方式及相關規定可前往申報平臺瀏覽或電洽412-1166。
- 五、如涉及稅籍登記部分，請於開始營業前檢送負責人身分證明文件、公司章程、許可業務之核准文件等影本洽營業所在地稽徵機關辦理；詳細文件請逕洽各地區國稅局。
- 六、對本行政處分如有不服，請依訴願法第14條及第58條規定，自行政處分書到達之次日起30日內，繕具訴願書，向本府遞送（以實際收受訴願書之日期為準，而非投郵日），並將副本抄送經濟部（地址：臺北市中正區福州街15號）。

※有關全民健康保險部分，請檢送相關表件自行向衛生福利部中央健康保險署各分區業務組，辦理有關投保單位變更事宜，相關規定請至該署全球資訊網(<https://www.nhi.gov.tw>)參閱。

※如需查詢公司登記公示資料可至本部「商工登記公示資料查詢服務」（網址為<https://findbiz.nat.gov.tw>）輸入統一編號或公司名稱即可查

喜利得股份有限公司

送審專用

FOR REVIEW

統一編號：22348814



第1頁共2頁





詢，公示資料查得之資料與本部公司登記資料一致，敬請多加利用。

正本：喜利得股份有限公司代理人：馬靜如律師

副本：喜利得股份有限公司 負責人：Laurent Camille Gimenez (無附件)

# 市長侯友宜

本案依分層負責規定授權業務主管決行



裝

訂

線



喜利得股份有限公司

送審專用

FOR REVIEW



# Certificate

Site certificate of main certificate Reg. no. H12455

SQS certifies herewith that the organisation mentioned below has at its disposal a management system which complies with the requirements of the normative directive listed.



**Hilti Taiwan Co., Ltd.**  
**24F., No. 16, Xinzhan Rd.,**  
**Banqiao Dist., New Taipei City 220,**  
**10060 Taipei Taiwan**

Scope of certification

**Sales**

Normative base

**ISO 9001:2015**

**Quality Management System**

喜利得股份有限公司

送審專用

FOR REVIEW



Reg. no. S39941

Validity 01.07.2019–30.06.2022  
Issue 01.07.2019

*A. Grisard*  
A. Grisard, President SQS

*F. Müller*  
F. Müller, CEO SQS



sqs.ch



Swiss Association for Quality and Management Systems (SQS)  
Bernstrasse 103, 3052 Zollikofen, Switzerland



## 附件四 HILTI HIT-RE100 TAF試驗室報告

- 黏著強度 ASTM C882/C882M-13a
- 吸水率 ASTM D570-98(2010)e1
- 接著強度 CNS 1010142 (1994)
- 抗壓強度 CNS 1010142 (1994)



試驗報告

報告編號：PO-20-01006C  
報告日期：2020年11月06日  
頁次：第1頁；共1頁

* 工程名稱：自行測試
* 業主：NA
* 監造單位：NA
* 承包商：NA
* 供料商：喜利得股份有限公司
* 樣品名稱：HIT-RE 100 化學黏著劑
* 取樣地點：NA
* 取樣人員：NA
送驗人員：喜利得股份有限公司(劉祥宇)
會驗人員：NA
* 委託單位：喜利得股份有限公司
* 聯絡資訊：NA
* 取樣日期：NA
收件日期：2020年10月08日
會驗日期：NA
試驗日期：2020年10月08日~2020年11月05日
※本報告中“*”為客戶提供之資訊

試驗結果：

序號	試驗項目	單位	試驗結果	試驗方法
1	黏著強度(2天)	kgf/cm <sup>2</sup>	441	ASTM C882/C882M-13a
2	吸水率 (23°C, 168小時)	%	0.30	ASTM D570-98(2010) <sup>e1</sup>
3	接著強度(標準狀態)	kgf/cm <sup>2</sup>	102	CNS 10142(1994)
4	抗壓強度	kgf/cm <sup>2</sup>	991	

註：1.TAF 認可範圍為吸水率，其餘則否。

----- END -----

喜利得股份有限公司  
**送審專用**  
**FOR REVIEW**

本報告結果塗改無效，未經書面許可，不可部分複製，但全文複製除外。  
本報告若有提供規範值時，該規範值僅供參考，且不得作為法律訴訟之憑證。  
本實驗室不提供報告之符合性聲明及量測不確定度，合格之判定以委託單位實際要求為主。  
本實驗室不參與抽樣，本報告結果僅對送驗樣品負責，送驗樣品批量及數量等資訊由委託單位提供。  
實驗室地址：新北市新莊區幸福東路65號 電話：02-2277-3996 傳真：02-2277-3596



報告簽署人



## 附件五 HILTI HIT-RE100防腐蝕報告







To

Hilti (Taiwan)  
台灣, 新北市  
板橋區新站路 16 號 24 樓

## HIT RE100 化學藥劑應用於後置植筋抗鋼筋腐蝕之說明

親愛的同事，

EAD 歐洲評估規範（EAD 330087-00-0601）根據表 A.1 對後置鋼筋連接進行了評估，以確認化學藥劑應用於後置鋼筋連接的各項性能表現。

其中鋼筋耐腐蝕性亦為其標準測試程序項目之一，並依據表 A.1 測試程序 17 中的測試流程 2.2.1.10 針對鋼筋耐腐蝕性進行測試，我們確認 Hilti HIT-RE100 化學錨固系統與預埋鋼筋系統於混凝土的鋼筋耐腐蝕性有相同表現，出具歐洲技術評估 ETA-15/0883 作為性能證明。

以上說明。

喜利得股份有限公司

順頌商祺

*Jean Lee*

Regional Product Manager A1



*Jacob Liu*

Product manager Taiwan

喜利得股份有限公司

送審專用

FOR REVIEW

喜利得(台灣)股份有限公司  
新站路 16 號 24 樓  
新北市板橋區 220 | 台灣



Approval body for construction products  
and types of construction

Bautechnisches Prüfamt

An institution established by the Federal and  
Laender Governments



## European Technical Assessment

**ETA-15/0883  
of 6 December 2017**

English translation prepared by DIBt - Original version in German language

### General Part

Technical Assessment Body issuing the  
European Technical Assessment:

Deutsches Institut für Bautechnik

Trade name of the construction product

Injection system Hilti HIT-RE 100

Product family  
to which the construction product belongs

Injection system for post-installed rebar connection

Manufacturer

Hilti AG  
Feldkircherstraße 100  
9494 Schaan  
FÜRSTENTUM LIECHTENSTEIN

Manufacturing plant

Hilti Werke

This European Technical Assessment  
contains

21 pages including 3 annexes which form an integral part  
of this assessment

This European Technical Assessment is  
issued in accordance with Regulation (EU)  
No 305/2011, on the basis of

EAD 330087-00-0601

This version replaces

ETA-15/0883 issued on 21 April 2016

喜利得股份有限公司

送審專用

FOR REVIEW

European Technical Assessment

ETA-15/0883

English translation prepared by DIBt

Page 2 of 21 | 6 December 2017

The European Technical Assessment is issued by the Technical Assessment Body in its official language. Translations of this European Technical Assessment in other languages shall fully correspond to the original issued document and shall be identified as such.

Communication of this European Technical Assessment, including transmission by electronic means, shall be in full. However, partial reproduction may only be made with the written consent of the issuing Technical Assessment Body. Any partial reproduction shall be identified as such.

This European Technical Assessment may be withdrawn by the issuing Technical Assessment Body, in particular pursuant to information by the Commission in accordance with Article 25(3) of Regulation (EU) No 305/2011.

喜利得股份有限公司

送審專用

FOR REVIEW

## Specific Part

### 1 Technical description of the product

The subject of this approval is the post-installed rebar connection, by anchoring or overlap connection joint, of reinforcing bars (rebars) in existing structures made of normal weight concrete, using the "Injection system Hilti HIT-RE 100" in accordance with the regulations for reinforced concrete construction.

Reinforcing bars made of steel with a diameter  $\phi$  from 8 to 32 mm according to Annex A and injection adhesive Hilti HIT-RE 100 are used for rebar connections. The rebar is placed into a drilled hole filled with injection mortar and is anchored via the bond between rebar, injection mortar and concrete.

The product description is given in Annex A.

### 2 Specification of the intended use in accordance with the applicable European assessment Document

The performances given in Section 3 are only valid if the anchor is used in compliance with the specifications and conditions given in Annex B.

The verifications and assessment methods on which this European Technical Assessment is based lead to the assumption of a working life of the rebar connections of at least 50 years. The indications given on the working life cannot be interpreted as a guarantee given by the producer, but are to be regarded only as a means for choosing the right products in relation to the expected economically reasonable working life of the works.

### 3 Performance of the product and references to the methods used for its assessment

#### 3.1 Mechanical resistance and stability (BWR 1)

Essential characteristic	Performance
Amplification factor $\alpha_{lb}$ , Bond resistance $f_{bd}$	See Annex C1

#### 3.2 Safety in case of fire (BWR 2)

Essential characteristic	Performance
Reaction to fire	Rebar connections satisfy requirements for Class A1
Resistance to fire	See Annex C2

### 4 Assessment and verification of constancy of performance (AVCP) system applied, with reference to its legal base

In accordance with European Assessment Document EAD No. 330087-00-0601, the applicable European legal act is: [96/582/EC].

The system(s) to be applied is (are): 1

喜利得股份有限公司

送審專用

FOR REVIEW

**5 Technical details necessary for the implementation of the AVCP system, as provided for in the applicable European Assessment Document**

Technical details necessary for the implementation of the AVCP system are laid down in the control plan deposited with Deutsches Institut für Bautechnik.

Issued in Berlin on 6 December 2017 by Deutsches Institut für Bautechnik

BD Dipl.-Ing. Andreas Kummerow  
Head of Department

*beglaubigt:*  
Lange

喜利得股份有限公司

送審專用

FOR REVIEW

## 附件六 ASTM E1512及E488 規範





# ACCEPTANCE CRITERIA FOR POST-INSTALLED ADHESIVE ANCHORS IN CONCRETE ELEMENTS

## AC308

### Approved May 2014

### Compliance date January 15, 2015

Previously approved December 2013, June 2013, February 2013, February 2012, June 2011, November 2009, June 2009, October 2008, August 2008, May 2008, February 2008, January 2008, October 2007, June 2007, February 2007, June 2006

(Previously editorially revised April 2014, October 2013, August 2013)

## PREFACE

Evaluation reports issued by ICC Evaluation Service, LLC (ICC-ES), are based upon performance features of the International family of codes. (Some reports may also reference older code families such as the BOCA National Codes, the Standard Codes, and the Uniform Codes.) Section 104.11 of the *International Building Code*® reads as follows:

The provisions of this code are not intended to prevent the installation of any materials or to prohibit any design or method of construction not specifically prescribed by this code, provided that any such alternative has been approved. An alternative material, design or method of construction shall be approved where the building official finds that the proposed design is satisfactory and complies with the intent of the provisions of this code, and that the material, method or work offered is, for the purpose intended, at least the equivalent of that prescribed in this code in quality, strength, effectiveness, fire resistance, durability and safety.

This acceptance criteria has been issued to provide interested parties with guidelines for demonstrating compliance with performance features of the codes referenced in the criteria. The criteria was developed through a transparent process involving public hearings of the ICC-ES Evaluation Committee, and/or on-line postings where public comment was solicited.

New acceptance criteria will only have an “approved” date, which is the date the document was approved by the Evaluation Committee. When existing acceptance criteria are revised, the Evaluation Committee will decide whether the revised document should carry only an “approved” date, or an “approved” date combined with a “compliance” date. The compliance date is the date by which relevant evaluation reports must comply with the requirements of the criteria. See the ICC-ES web site for more information on compliance dates.

If this criteria is a revised edition, a solid vertical line (|) in the margin within the criteria indicates a change from the previous edition. A deletion indicator (→) is provided in the margin where any significant wording has been deleted.

ICC-ES may consider alternate criteria for report approval, provided the report applicant submits data demonstrating that the alternate criteria are at least equivalent to the criteria set forth in this document, and otherwise demonstrate compliance with the performance features of the codes. ICC-ES retains the right to refuse to issue or renew any evaluation report, if the applicable product, material, or method of construction is such that either unusual care with its installation or use must be exercised for satisfactory performance, or if malfunctioning is apt to cause injury or unreasonable damage.

NOTE: The Preface for ICC-ES acceptance criteria was revised in July 2011 to reflect changes in policy.

*Acceptance criteria are developed for use solely by ICC-ES for purposes of issuing ICC-ES evaluation reports.*

Copyright © 2014

喜利得股份有限公司

送審專用

FOR REVIEW

# ACCEPTANCE CRITERIA FOR ADHESIVE ANCHOR SYSTEMS IN CONCRETE ELEMENTS (AC308)

## 1.0 INTRODUCTION

**1.1 Purpose:** The purpose of this acceptance criteria is to establish requirements for adhesive anchors, torque-controlled adhesive anchors, and post-installed reinforcing bars in concrete elements to be recognized in an ICC Evaluation Service, LLC (ICC-ES), evaluation report under the 2012, 2009 and 2006 *International Building Code*® (IBC), and the 2012, 2009 and 2006 *International Residential Code*® (IRC), . Bases of recognition are IBC Section 104.11 and IRC Section R104.11.

The reason for the development of this criteria is to allow for recognition of the use of adhesive anchors in concrete to create connections between structural concrete and attachments and the use of post-installed reinforcing bars in accordance with the code.

**1.2 Scope:** Anchors recognized under this criteria are alternatives to anchors permitted by Section 1913 of the IBC. The anchors recognized in this criteria may also be used where an engineered design is permitted in accordance with Section R301.1.2 of the IRC. Post-installed reinforcing bar systems recognized under this criteria are alternatives to cast-in-place reinforcing bars as governed by ACI 318.

**1.3 Codes and Referenced Standards:** Where standards are referenced in this criteria, these standards shall be applied consistently with the code upon which compliance is based. Standards editions listed in this section apply to all codes. Where standards editions are not listed in this section, Table 1 summarizes the specific date applicable to each code.

**1.3.1** 2012, 2009 and 2006 *International Building Code*® (IBC), International Code Council.

**1.3.2** 2012, 2009 and 2006 *International Residential Code*® (IRC), International Code Council.

**1.3.3** ACI 318, Building Code Requirements for Structural Concrete, American Concrete Institute.

**1.3.4** ACI 355.4, Acceptance Criteria for Qualification of Post-installed Adhesive Anchors in Concrete, American Concrete Institute.

**1.3.5** ACI 211.1-91 (2002), Standard Practice for Selecting Proportions for Normal, Heavyweight and Mass Concrete, American Concrete Institute.

**1.3.6** ANSI B 212.15-1994, American National Standard for Cutting Tools – Carbide Tipped Masonry Drills and Blanks for Carbide-Tipped Masonry Drills, American National Standards Institute.

**1.3.7** ASTM A153, Standard Specification for Zinc Coating (Hot-Dip) on Iron and Steel Hardware, ASTM International.

**1.3.8** ASTM A193/A 193 M-06a, Standard Specification for Alloy-Steel and Stainless Steel Bolting Materials for High Temperature or High Pressure Service and Other Special Purpose Applications, ASTM International.

**1.3.9** ASTM A490-04a, Standard Specification for Heat-Treated Steel Structural Bolts, 150 ksi Minimum Tensile Strength, ASTM International.

**1.3.10** ASTM B695, Standard Specification for Coatings of Zinc Mechanically Deposited on Iron and Steel, ASTM International.

**1.3.11** ASTM C31, Standard Practice for Making and Curing Concrete Test Specimens in the Field, ASTM International.

**1.3.12** ASTM C33-03, Standard Specification for Concrete Aggregates, ASTM International.

**1.3.13** ASTM C39, Standard Test Method for Compressive Strength of Cylindrical Concrete Specimens, ASTM International.

**1.3.14** ASTM C42, Standard Test Method for Obtaining and Testing Drilled Cores and Sawed Beams of Concrete, ASTM International.

**1.3.15** ASTM C150, Standard Specification for Portland Cement, ASTM International.

**1.3.16** ASTM C330, Standard Specification for Lightweight Aggregates for Structural Concrete, ASTM International.

**1.3.17** ASTM C882-05, Standard Test Method for Bond Strength of Epoxy-Resin Systems Used with Concrete by Slant Shear, ASTM International.

**1.3.18** ASTM D1875-03, Standard Test Method for Density of Adhesives in Fluid Form, ASTM International.

**1.3.19** ASTM D2471-99, Standard Test Method for Gel Time and Peak Exothermic Temperature of Reacting Thermosetting Resins, ASTM International.

**1.3.20** ASTM D2556-93a(2005), Standard Test Method for Apparent Viscosity of Adhesives Having Shear-Rate-Dependent Flow Properties, ASTM International.

**1.3.21** ASTM E488-96(2003), Standard Test Method for Strength of Anchors in Concrete and Masonry Elements, ASTM International.

**1.3.22** ASTM E1252-98(2002), Standard Practice for General Techniques for Obtaining Infrared Spectra for Qualitative Analysis, ASTM International.

**1.3.23** ASTM E1512-01, Standard Test Methods for Testing Bond Performance of Adhesive-Bonded Anchors, ASTM International.

**1.3.24** ASTM F606-05, Standard Test Methods for Determining the Mechanical Properties of Externally and Internally Threaded Fasteners, Washers, and Rivets, ASTM International.

**1.3.25** ASTM F1080-93(2002), Standard Test Method for Determining the Consistency of Viscous Liquids Using a Consistometer, ASTM International.

**1.3.26** EB001, Design and Control of Concrete Mixtures, 14<sup>th</sup> edition, 2002, Portland Cement Association.

## 1.4 Definitions:

**1.4.1 ACI 355.4:** The referenced document in Section 1.3.4 as amended by Annex 1. 喜利得股份有限公司

**1.4.2 Anchor Test Series:** A group of identical anchors tested under identical conditions. Identical anchors originate from the same adhesive formulation. 送審專用

